

DEUTSCH FILTER CONNECTORS

Control of EMI and Voltage Transients
with Rugged, Weight-Saving Solutions



DEUTSCH FILTER CONNECTORS

Control of EMI with Rugged, Weight-Saving Solutions

| | | | |
|--|---------------------------|--|------------------------|
| INTRODUCTION | 3-4 | FILTERING TECHNOLOGY | |
| FILTER CONNECTOR STANDARD SERIES | | EMI Filter Connectors— Planar Array Technology | 51-54 |
| MIL-DTL 38999 Series I (H91 Series) | 5-8 | Transient Protection | 55-57 |
| MIL-DTL 38999 Series I.5 (HDJ Series) | 9-12 | | |
| MIL-DTL 38999 Series II (H92 Series) | 13-16 | REFERENCE | |
| MIL-DTL 38999 Series III (H93 Series) | 17-20 | Intermateability | 58 |
| MIL-DTL 38999 Series IV (H94 Series) | 21-24 | Using DEUTSCH Filter Connectors | 59 |
| MIL-STD-38999 1.5 derived (AS Series) | 25-28 | Wire Preparation | 60 |
| MIL-STD-1560 Insert Arrangements (for 38999 Connectors) | 29-30 | Crimping | 61 |
| MIL-DTL-26482 Series II (RR Series) Insert Arrangements | 31-34 35 | Acceptance Criteria/Voltage Drop Test | 62-63 |
| EN3646 (FDBA Series) Insert Arrangements | 36-39 40 | Contact Insertion/Extraction | 64-65 |
| ESC10, 15 and EN2997 (983 Series) Insert Arrangements | 41-44 45 | Best Practices | 66 |
| ESC11, 16 and EN2997 (984 Series) Insert Arrangements | 46-47 48 | Crimp Contacts, Tooling, and Sealing Plugs | 67 |
| | | Wire Gauge Data | 68-69 |
| ADDITIONAL FILTERING CONNECTOR CAPABILITIES | | Typical DEUTSCH Filter Connector Part Number Scheme | 70 |
| Additional Connector Families | 49 | GLOSSARY | 71 |
| ARINC 600 | | | |
| MIL-DTL-5015 | | | |
| MIL-DTL-81511 | | | |
| VG95326 | | | |
| VG95328 | | | |
| Additional Connector Styles | 50 | CONFIGURATION SHEET | Back Cover Flap |
| Adapters | | | |
| Feedthrough | | | |
| Hermetic | | | |
| Headers | | | |

TE Components . . . TE Technology . . . TE Know-how . . .

AMP | Agastat | CII | Hartman | Kilovac | Microdot | Nanonics | Polamco | Raychem | Rochester | DEUTSCH
SEACON Phoenix | L.L. Rowe | Phoenix Optix | AFP | SEACON

Get your product to market faster with a smarter, better solution.



Introduction

THE PATH TO EMC PASSES THROUGH DEUTSCH FILTER CONNECTORS

DEUTSCH filter connectors from TE Connectivity (TE) provide the high-performance you need to counter conducted electromagnetic interference and maintain signal integrity. Typically deployed at the input/output point of an electronic component, DEUTSCH filter connectors offer an effective means to prevent EMI generated within the enclosure from being conducted outside. They also work to prevent noise from elsewhere from being conducted into the box.

Pass the Signals, Not the Noise

DEUTSCH filter connectors use low-pass filters to reduce the level of conducted EMI from sources such as radio transmitters, radar systems, load switching, etc. The filters allow power and control signals to pass while attenuating EMI. EMI frequencies typically range from several kilohertz to many gigahertz. Low-pass filters use capacitors and inductors in various configurations, with the capacitive and inductive values being selected to adjust the range of frequencies filtered, achieve the level of attenuation, and accommodate the source and load impedances.

Application Advantages of Filter Connectors

- **Space Savings.** Because the filter is built into a standard connector footprint, additional parts are not required in other parts of the system, either a discrete filter or filter components on a pc board. The use of a filter connector eliminates the “dirty area” required by an additional printed circuit board with EMI filters.
- **Weight Savings.** With the filter inside the connector, rather than on a board, equipment can potentially be smaller and lighter in weight.
- **Rugged Reliability.** Not only is the filter connector inherently rugged, system reliability can also be enhanced by eliminating the need for additional components and related solder joints.
- **Reduced Assembly Time.** Installing a filter connector into a system is the same as installing a standard connector, saving any additional manufacturing or assembly steps for an external filter.

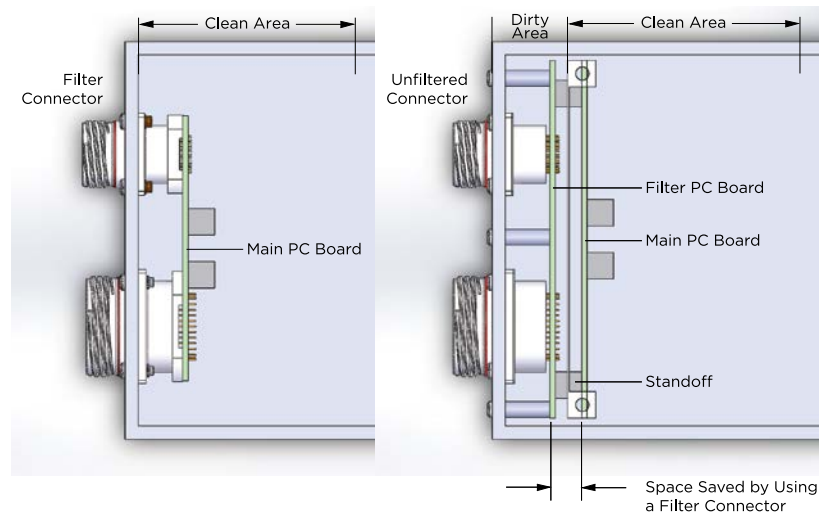

Design Advantages

- **Filtering Flexibility.** Each line of the connector can be custom filtered.
- **Complete Filtering Solution.** Filter connectors offer a complete plug-and-go solution.
- **Fully Tested Prior to Installation.** The need for post-installation testing is eliminated.



Transient Protection Made Easy

DEUTSCH connectors are also available with transient protection from high-voltage electromagnetic pulses, including downstream suppression of:

- Electromagnetic Pulses (EMP)
- Lightning (LEMP)
- Electrostatic Discharges (ESD)
- High-Altitude Electromagnetic Pulse (HEMP)
- Nuclear Electromagnetic Pulse (NEMP)

Full Range of Materials and Platings

Connectors are generally available in aluminum, stainless steel, and composite shells. Plating choices range from traditional olive drab cadmium and nickel to the latest RoHS-compliant finishes, including nickel PTFE and black zinc-nickel.

DEUTSCH . . . Design Engineering . . . Quality . . . Service . . .

Our expertise in filtering technologies and in-depth understanding of application help lighten your engineering load

Our engineering support from concept through manufacturing, quick turn of samples, and reliable delivery of reliable products. We can also provide custom and semicustom solutions fast.

Typical Applications for Filter Connectors

Aerospace Control Systems

- De-Icing Systems
- Flight Control Systems
- Lighting Control
- Cockpit Display Equipment

Aerospace Power Systems

- Engine Power Lines
- Engine Control Systems
- Fuel Systems

Communications

- Radio Communications Systems
- Radar Systems
- Electronic Jamming Systems
- Military Vision Equipment

Control Systems

- Avionics Systems
- CANbus Systems

Military Ground Vehicles

- Power Distribution Systems
- Vehicle Engine Power and Control

UAVs

- UAV Command Control
- Weapons Systems
- Antenna Connections



DEUTSCH H91 Series Filter Connectors

MIL-DTL-38999 SERIES I



MIL-DTL-38999 Series I connectors are subminiature, environmental-class connectors with high and medium-density insert arrangements. They are used where a quick-disconnect coupling system is required for blind mating or other problem areas. The bayonet coupling requires 1/3 turn to mate fully. Available with crimp contacts, PC tails, solder cups and headers, they feature various plating options available and five keying options.

SPECIFICATIONS

MATING COMPATIBILITY

- MIL-DTL 38999 Series I connectors
- DEUTSCH DJT Series connectors
- DEUTSCH 999-1 and HDJ Series connectors

RELIABLE

- Positive three-point bayonet coupling
- 100% scoop proof
- RFI shell-to-shell continuity

VERSATILE

- Wide range of connector shell configurations
- Configurable filter topologies

DESIGNED FOR HARSH ENVIRONMENTS

- Vibration and shock
- Temperature extremes
- High humidity
- Altitude
- Salt spray

Environmental

- **Temperature Range:** -55°C to 125°C
- **Physical Shock:** Typical to EIA-364-27 test condition C
- **Vibration:** Typical to EIA-364-28
- **Fungus Resistance:** Based on MIL-STD-810
- **Fluid Immersion:** Typically tested to EIA-364-10
- **Salt Spray:** Typically based on EIA/ECA-364-26
- **Humidity:** Typically EIA-364-31 test method IV
- **Durability:** 1500 cycles for Classes J and M and 500 cycles for all other connectors as per 38999 spec

Electrical

- **Grounded Line Resistance (Typ.):** 15 mΩ
- **Insulation Resistance (Typ.):** >5 GΩ
- **Dielectric Withstand (Typ.):** <5 μA
- **DWV:** up to 2000 VDC
- **Working Voltage:** up to 2000 VDC
- **Typical Test Specifications Used:**
MIL-STD-810: Test Method Standard
MIL-STD-202: Electrical & Electronic Component Parts
RTCA DO-160: Test Procedures for Airborne Equipment
EIA-364: Electrical Connector & Socket Test Procedures

Filtering

- **Capacitance Range:** 20 pF to 4 μF
- **Capacitance Tolerance:** Typically 20%
- **Unfiltered Line Cap (Typ.):** 15 pF
- **Filtering Topologies:** L, C, LC, CL, Pi, T, Double T

Transient protection available as per RTCA Publication DO 160 (see page 55).



DEUTSCH H91 Series Filter Connectors

MIL-DTL-38999 SERIES I

Jam Nut Receptacle Connectors

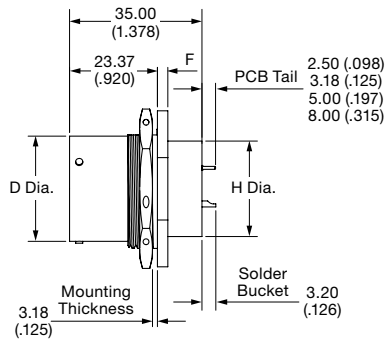

Single Flange

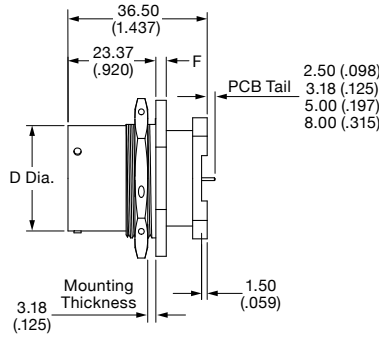

Double Flange

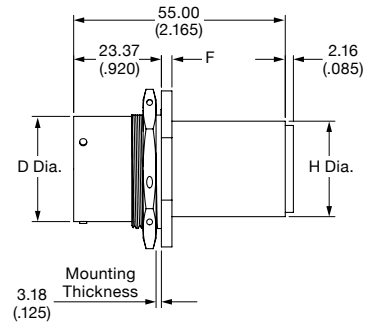

Single Flange, Crimp Contacts

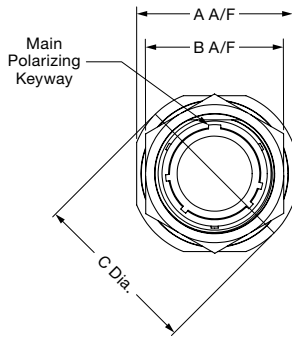

Front View

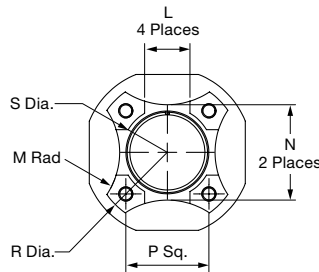

Double Flange Footprint

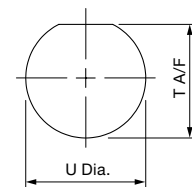

Recommended Panel Cutout

| Shell Size | A A/F | B A/F | C Dia. | D Dia. | F | H Dia. | L | M Rad | N | P Sq. | R Dia. | S Dia. | Mounting Dims | |
|------------|------------------|------------------|------------------|------------------|-----------------|------------------|------------------|------------------|------------------|------------------|------------------|------------------|------------------|------------------|
| | | | | | | | | | | | | | T Dia. | U Dia. Max. |
| 9 | 27.38 (1.078) | 22.64 (0.891) | 30.59 (1.204) | 14.48 (0.570) | | 15.67 (0.616) | 8.00 (0.315) | 9.00 (0.354) | 15.50 (0.610) | 14.00 (0.551) | 27.06 (1.065) | 14.34 (0.565) | 16.99 (0.669) | 17.70 (0.697) |
| 11 | 32.16 (1.266) | 25.83 (1.017) | 35.34 (1.391) | 17.73 (0.698) | | 15.67 (0.616) | 8.00 (0.315) | 9.00 (0.354) | 15.50 (0.610) | 14.00 (0.551) | 27.06 (1.065) | 14.34 (0.565) | 19.53 (0.769) | 20.88 (0.822) |
| 13 | 35.34 (1.391) | 30.61 (1.205) | 38.51 (1.516) | 21.54 (0.848) | 3.05 (0.120) | 18.85 (0.742) | 8.00 (0.315) | 12.00 (0.472) | 18.65 (0.734) | 17.00 (0.669) | 32.06 (1.262) | 17.42 (0.686) | 24.26 (0.955) | 25.58 (1.007) |
| 15 | 38.51 (1.516) | 33.75 (1.329) | 41.69 (1.641) | 24.71 (0.973) | | 22.22 (0.874) | 12.00 (0.472) | 18.00 (0.709) | 22.00 (0.866) | 19.00 (0.748) | 35.06 (1.380) | 20.72 (0.816) | 27.53 (1.084) | 28.80 (1.134) |
| 17 | 41.69 (1.641) | 36.95 (1.455) | 44.86 (1.766) | 27.89 (1.098) | | 25.45 (1.001) | 12.00 (0.472) | 20.00 (0.787) | 25.25 (0.994) | 22.00 (0.866) | 39.06 (1.538) | 23.89 (0.941) | 30.68 (1.208) | 31.98 (1.259) |
| 19 | 46.43 (1.828) | 40.10 (1.579) | 49.64 (1.954) | 30.61 (1.205) | | 28.57 (1.125) | 16.00 (0.630) | 22.00 (0.866) | 28.40 (1.118) | 25.00 (0.984) | 42.06 (1.656) | 26.43 (1.041) | 33.86 (1.333) | 35.15 (1.383) |
| 21 | 49.64 (1.954) | 43.31 (1.705) | 52.78 (2.078) | 33.78 (1.330) | | 31.75 (1.250) | 16.00 (0.630) | 22.00 (0.866) | 31.55 (1.242) | 27.00 (1.063) | 45.06 (1.774) | 29.58 (1.165) | 37.06 (1.459) | 38.28 (1.507) |
| 23 | 52.78 (2.078) | 46.45 (1.829) | 55.99 (2.204) | 36.96 (1.455) | 3.84 (0.151) | 34.72 (1.367) | 16.00 (0.630) | 22.00 (0.866) | 34.50 (1.358) | 29.00 (1.142) | 48.06 (1.892) | 32.76 (1.290) | 40.01 (1.575) | 41.50 (1.634) |
| 25 | 55.99 (2.204) | 51.23 (2.017) | 59.13 (2.328) | 40.13 (1.580) | | 37.50 (1.476) | 16.00 (0.630) | 24.00 (0.945) | 37.30 (1.469) | 31.00 (1.221) | 51.06 (2.010) | 35.83 (1.411) | 43.41 (1.709) | 44.68 (1.759) |

See page 29 for insert arrangements and back cover for configuration sheet.



DEUTSCH H91 Series Filter Connectors

MIL-DTL-38999 SERIES I

Square Flange Receptacle Connectors

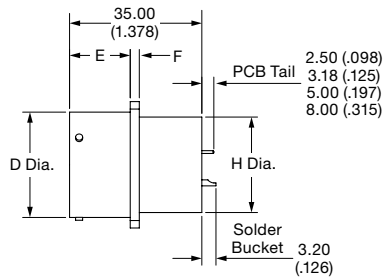

Single Flange

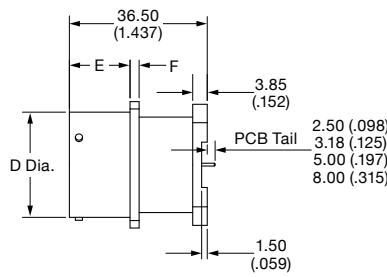

Double Flange

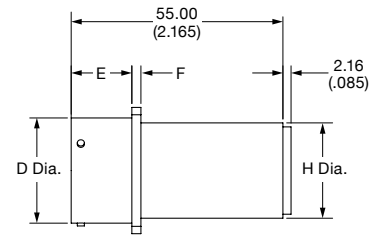

Single Flange, Crimp Contacts

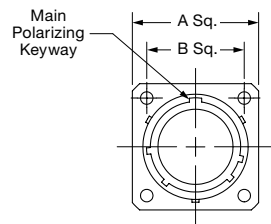

Front View

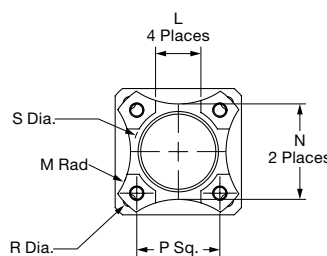

Double Flange Footprint

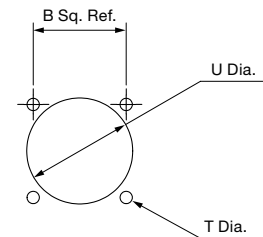

Square Flange Mounting

| Shell Size | A Sq. | B Sq. | D Dia. | E Max. | F Max. | H Dia. Max. | L Ref. | M Rad Ref. | N Ref. | P Sq. | R Dia. | S Dia. | Mounting Holes | |
|------------|------------------|------------------|------------------|------------------|-----------------|------------------|------------------|------------------|------------------|------------------|------------------|------------------|-----------------|------------------|
| | | | | | | | | | | | | | T Dia. | U Dia. |
| 9 | 24.34 (0.958) | 18.26 (0.719) | 14.48 (0.570) | | | 15.67 (0.616) | 8.00 (0.315) | 9.00 (0.354) | 15.50 (0.610) | 14.00 (0.551) | 27.06 (1.065) | 14.34 (0.565) | | 16.66 (0.656) |
| 11 | 26.70 (1.051) | 20.62 (0.812) | 17.73 (0.698) | | | 15.67 (0.616) | 8.00 (0.315) | 9.00 (0.354) | 15.50 (0.610) | 14.00 (0.551) | 27.06 (1.065) | 14.34 (0.565) | | 20.22 (0.796) |
| 13 | 29.09 (1.145) | 23.01 (0.906) | 21.54 (0.848) | 16.05 (0.632) | 2.54 (0.100) | 18.85 (0.742) | 8.00 (0.315) | 12.00 (0.472) | 18.65 (0.734) | 17.00 (0.669) | 32.06 (1.262) | 17.42 (0.686) | | 23.42 (0.922) |
| 15 | 31.47 (1.238) | 24.61 (0.969) | 24.71 (0.973) | | | 22.22 (0.874) | 12.00 (0.472) | 18.00 (0.709) | 22.00 (0.866) | 19.00 (0.748) | 35.06 (1.380) | 20.72 (0.816) | 3.25 (0.128) | 26.59 (1.047) |
| 17 | 33.83 (1.332) | 26.97 (1.062) | 27.89 (1.098) | | | 25.45 (1.001) | 12.00 (0.472) | 20.00 (0.787) | 25.25 (0.994) | 22.00 (0.866) | 39.06 (1.538) | 23.89 (0.941) | | 30.96 (1.219) |
| 19 | 37.04 (1.458) | 29.36 (1.156) | 30.61 (1.205) | | | 28.57 (1.125) | 16.00 (0.630) | 22.00 (0.866) | 28.40 (1.118) | 25.00 (0.984) | 42.06 (1.656) | 26.43 (1.041) | | 32.94 (1.297) |
| 21 | 40.17 (1.581) | 31.75 (1.250) | 33.78 (1.330) | | | 31.75 (1.250) | 16.00 (0.630) | 22.00 (0.866) | 31.55 (1.242) | 27.00 (1.063) | 45.06 (1.774) | 29.58 (1.165) | | 36.12 (1.422) |
| 23 | 43.39 (1.708) | 34.93 (1.375) | 36.96 (1.455) | 15.29 (0.602) | 3.30 (0.130) | 34.72 (1.367) | 16.00 (0.630) | 22.00 (0.866) | 34.50 (1.358) | 29.00 (1.142) | 48.06 (1.892) | 32.76 (1.290) | | 39.29 (1.547) |
| 25 | 46.53 (1.831) | 38.1 (1.500) | 40.13 (1.580) | | | 37.50 (1.476) | 16.00 (0.630) | 24.00 (0.945) | 37.30 (1.469) | 31.00 (1.221) | 51.06 (2.010) | 35.83 (1.411) | 3.91 (0.154) | 42.47 (1.672) |

See page 29 for insert arrangements and back cover for configuration sheet.



DEUTSCH H91 Series Filter Connectors

MIL-DTL-38999 SERIES I

Plug Connectors

| Shell Size | A Dia. |
|------------|------------------|
| 9 | 23.82 (0.938) |
| 11 | 26.19 (1.031) |
| 13 | 28.57 (1.125) |
| 15 | 30.96 (1.219) |
| 17 | 33.32 (1.312) |
| 19 | 36.52 (1.438) |
| 21 | 39.67 (1.562) |
| 23 | 42.87 (1.688) |
| 25 | 46.02 (1.812) |

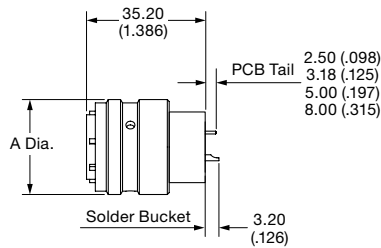

PCB/Solder Bucket Contacts

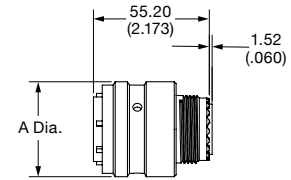

Crimp Contacts

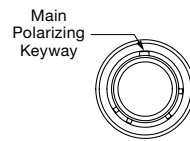

Front View

Keying Options

(Viewed from Mating Face of the Receptacle Connector)

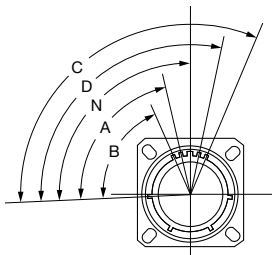

| Shell Size | Key Position | | | | |
|------------|--------------|----|----|-----|-----|
| | N | A | B | C | D |
| 9 | 95 | 77 | — | — | 113 |
| 11 | 95 | 81 | 67 | 123 | 109 |
| 13 | 95 | 75 | 63 | 127 | 115 |
| 15 | 95 | 74 | 61 | 129 | 116 |
| 17 | 95 | 77 | 65 | 125 | 113 |
| 19 | 95 | 77 | 65 | 125 | 113 |
| 21 | 95 | 77 | 65 | 125 | 113 |
| 23 | 95 | 80 | 69 | 121 | 110 |
| 25 | 95 | 80 | 69 | 121 | 110 |

See page 29 for insert arrangements and back cover for configuration sheet.



DEUTSCH HDJ Series Filter Connectors

MIL-DTL-38999 SERIES I.5

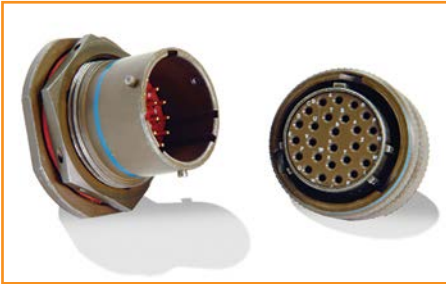

DEUTSCH HDJ Series connectors are subminiature environment-class connectors with high and medium-density insert arrangements. They are based on MIL-DTL-38999 Series I coupling interface lengths and Series II diameters. They are used where a quick-disconnect coupling system is required for blind mating or other problem areas. The bayonet coupling requires 1/3 turn to mate fully. Available with crimp contacts, PC tails, solder cups and headers, they feature various plating options available and five keying options.

MATING COMPATIBILITY

- MIL-DTL-38999 Series 1.5 connectors
- DEUTSCH HDJ and AS Series connectors
- JN1003 connectors

RELIABLE

- 100% scoop proof
- Positive bayonet coupling
- RFI shell-to-shell coupling

VERSATILE

- Wide range of connector shell configurations
- Configurable filter topologies

DESIGNED FOR HARSH ENVIRONMENTS

- Vibration and shock
- Temperature extremes
- High humidity
- Altitude
- Salt spray

SPECIFICATIONS

Environmental

- **Temperature Range:** -55°C to 125°C
- **Physical Shock:** Typical to EIA-364-27 test condition C
- **Vibration:** Typical to EIA-364-28
- **Fungus Resistance:** Based on MIL-STD-810
- **Fluid Immersion:** Typically tested to EIA-364-10
- **Salt Spray:** Typically based on EIA/ECA-364-26
- **Humidity:** Typically EIA-364-31 test method IV
- **Durability:** 1500 cycles for Classes J and M and 500 cycles for all other connectors as per 38999 spec

Electrical

- **Grounded Line Resistance (Typ.):** 15 mΩ
- **Insulation Resistance (Typ.):** >5 GΩ
- **Dielectric Withstand (Typ.):** <5 μA
- **DWV:** up to 2000 VDC
- **Working Voltage:** up to 2000 VDC
- **Typical Test Specifications Used:**
MIL-STD-810: Test Method Standard
MIL-STD-202: Electrical & Electronic Component Parts
RTCA DO-160: Test Procedures for Airborne Equipment
EIA-364: Electrical Connector & Socket Test Procedures

Filtering

- **Capacitance Range:** 20 pF to 4 μF
- **Capacitance Tolerance:** Typically 20%
- **Unfiltered Line Cap (Typ.):** 15 pF
- **Filtering Topologies:** L, C, LC, CL, Pi, T, Double T

Transient protection available as per RTCA Publication DO 160 (see page 55).



DEUTSCH HDJ Series Filter Connectors

MIL-DTL-38999 SERIES I.5

Jam Nut Receptacle Connectors

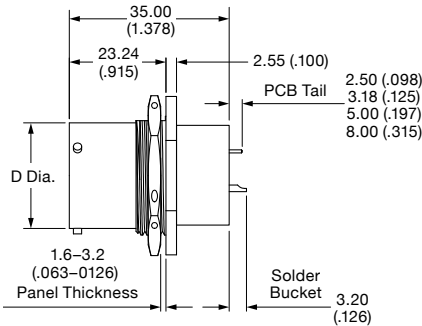

Single Flange

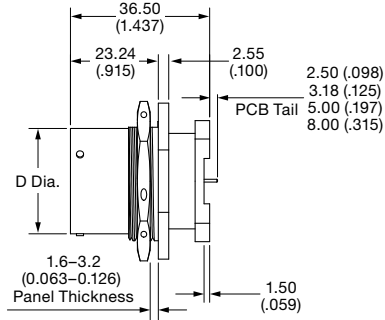

Double Flange

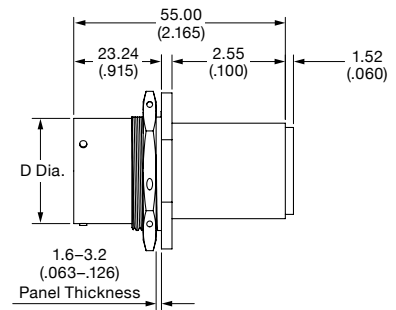

Single Flange, Crimp Contacts

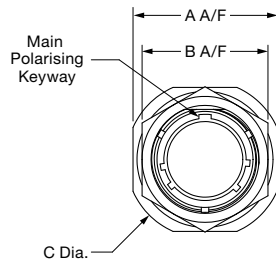

Front View

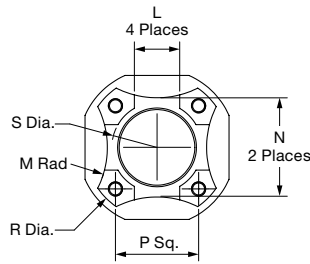

Double Flange Footprint

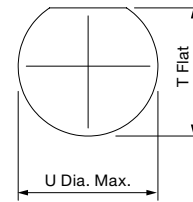

Recommended Panel Cutout

| Shell Size | A Sq Max. | B Sq. | D Dia. | L Ref. | M Rad Ref. | N Ref. | P Sq. | R Dia. | S Dia. | Mounting Dims | |
|------------|------------------|------------------|------------------|------------------|------------------|------------------|------------------|------------------|------------------|------------------|------------------|
| | | | | | | | | | | T Flat | U Dia. |
| 8 | 21.03 (0.828) | 15.08 (0.594) | 12.00 (0.472) | 8.00 (0.315) | 9.00 (0.354) | 15.50 (0.610) | 14.00 (0.551) | 27.06 (1.065) | 14.34 (0.565) | 13.62 (0.536) | 14.53 (0.572) |
| 10 | 24.23 (0.954) | 18.26 (0.719) | 15.00 (0.590) | 8.00 (0.315) | 9.00 (0.354) | 15.50 (0.610) | 14.00 (0.551) | 27.06 (1.065) | 14.34 (0.565) | 16.79 (0.661) | 17.70 (0.697) |
| 12 | 26.59 (1.047) | 20.62 (0.812) | 19.05 (0.750) | 8.00 (0.315) | 12.00 (0.472) | 18.65 (0.734) | 17.00 (0.669) | 32.06 (1.262) | 17.42 (0.686) | 21.00 (0.826) | 22.50 (0.886) |
| 14 | 28.98 (1.141) | 23.02 (0.906) | 22.22 (0.875) | 12.00 (0.472) | 18.00 (0.709) | 22.00 (0.866) | 19.00 (0.748) | 35.06 (1.380) | 20.72 (0.816) | 24.08 (0.948) | 25.70 (1.012) |
| 16 | 31.34 (1.234) | 24.58 (0.968) | 25.40 (1.000) | 12.00 (0.472) | 20.00 (0.787) | 25.25 (0.994) | 22.00 (0.866) | 39.06 (1.538) | 23.89 (0.941) | 27.23 (1.072) | 28.83 (1.135) |
| 18 | 33.73 (1.328) | 26.98 (1.062) | 28.57 (1.125) | 16.00 (0.630) | 22.00 (0.866) | 28.40 (1.118) | 25.00 (0.984) | 42.06 (1.656) | 26.43 (1.041) | 30.41 (1.197) | 32.01 (1.260) |
| 20 | 36.91 (1.453) | 29.36 (1.156) | 31.75 (1.250) | 16.00 (0.630) | 22.00 (0.866) | 31.55 (1.242) | 27.00 (1.063) | 45.06 (1.774) | 29.58 (1.165) | 33.58 (1.322) | 35.18 (1.385) |
| 22 | 40.08 (1.578) | 31.76 (1.250) | 34.92 (1.375) | 16.00 (0.630) | 22.00 (0.866) | 34.50 (1.358) | 29.00 (1.142) | 48.06 (1.892) | 32.76 (1.290) | 36.95 (1.455) | 38.36 (1.510) |
| 24 | 43.26 (1.703) | 34.92 (1.375) | 38.10 (1.500) | 16.00 (0.630) | 24.00 (0.945) | 37.30 (1.469) | 31.00 (1.221) | 51.06 (2.010) | 35.83 (1.411) | 39.93 (1.572) | 41.53 (1.635) |

See page 29 for insert arrangements and back cover for configuration sheet.



DEUTSCH HDJ Series Filter Connectors

MIL-DTL-38999 SERIES I.5

Square Flange Receptacle Connectors

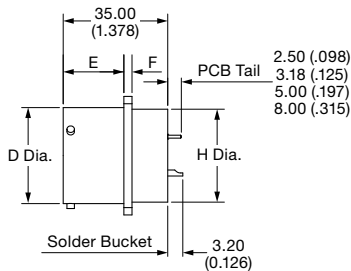

Single Flange

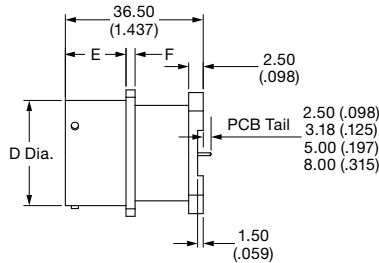

Double Flange

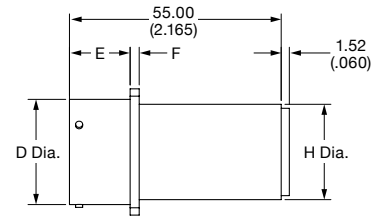

Single Flange, Crimp Contacts

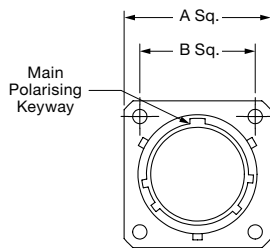

Front View

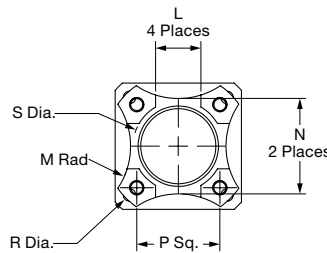

Double Flange Footprint

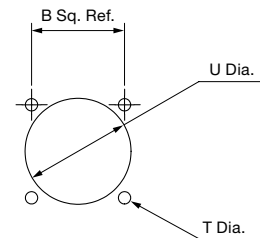

Square Flange Mounting

| Shell Size | A Sq. Max. | B Sq. | D Dia. | E | F | H Dia. Max | L Ref. | M Rad Ref. | N Ref. | P Sq. | R Dia. | S Dia. | Mounting Dims | |
|------------|------------------|------------------|------------------|------------------|-----------------|------------------|------------------|------------------|------------------|------------------|------------------|------------------|-----------------|------------------|
| | | | | | | | | | | | | | T Dia. | U Dia. Max. |
| 8 | 21.03 (0.828) | 15.08 (0.594) | 12.00 (0.472) | | | 11.91 (0.469) | 8.00 (0.315) | 9.00 (0.354) | 15.50 (0.610) | 14.00 (0.551) | 27.06 (1.065) | 14.34 (0.565) | 3.60 (0.142) | 13.70 (0.539) |
| 10 | 24.23 (0.954) | 18.26 (0.719) | 15.00 (0.590) | | | 15.09 (0.594) | 8.00 (0.315) | 9.00 (0.354) | 15.50 (0.610) | 14.00 (0.551) | 27.06 (1.065) | 14.34 (0.565) | 3.60 (0.142) | 16.90 (0.665) |
| 12 | 26.59 (1.047) | 20.62 (0.812) | 19.05 (0.750) | 16.05 (0.632) | 2.16 (0.085) | 18.26 (0.719) | 8.00 (0.315) | 12.00 (0.472) | 18.65 (0.734) | 17.00 (0.669) | 32.06 (1.262) | 17.42 (0.686) | 3.60 (0.142) | 21.00 (0.827) |
| 14 | 28.98 (1.141) | 23.02 (0.906) | 22.22 (0.875) | 16.05 (0.632) | 2.16 (0.085) | 21.44 (0.844) | 12.00 (0.472) | 18.00 (0.709) | 22.00 (0.866) | 19.00 (0.748) | 35.06 (1.380) | 20.72 (0.816) | 3.60 (0.142) | 24.20 (0.953) |
| 16 | 31.34 (1.234) | 24.58 (0.968) | 25.40 (1.000) | 16.05 (0.632) | 2.16 (0.085) | 24.61 (0.969) | 12.00 (0.472) | 20.00 (0.787) | 25.25 (0.994) | 22.00 (0.866) | 39.06 (1.538) | 23.89 (0.941) | 3.60 (0.142) | 27.30 (1.075) |
| 18 | 33.73 (1.328) | 26.98 (1.062) | 28.57 (1.125) | 16.05 (0.632) | 2.16 (0.085) | 27.38 (1.078) | 16.00 (0.630) | 22.00 (0.866) | 28.40 (1.118) | 25.00 (0.984) | 42.06 (1.656) | 26.43 (1.041) | 3.60 (0.142) | 30.50 (1.201) |
| 20 | 36.91 (1.453) | 29.36 (1.156) | 31.75 (1.250) | 16.05 (0.632) | 2.16 (0.085) | 30.56 (1.203) | 16.00 (0.630) | 22.00 (0.866) | 31.55 (1.242) | 27.00 (1.063) | 45.06 (1.774) | 29.58 (1.165) | 3.60 (0.142) | 33.70 (1.327) |
| 22 | 40.08 (1.578) | 31.76 (1.250) | 34.92 (1.375) | 15.29 (0.602) | 2.92 (0.115) | 33.73 (1.328) | 16.00 (0.630) | 22.00 (0.866) | 34.50 (1.358) | 29.00 (1.142) | 48.06 (1.892) | 32.76 (1.290) | 3.60 (0.142) | 36.90 (1.453) |
| 24 | 43.26 (1.703) | 34.92 (1.375) | 38.10 (1.500) | 15.29 (0.602) | 2.92 (0.115) | 36.91 (1.453) | 16.00 (0.630) | 24.00 (0.945) | 37.30 (1.469) | 31.00 (1.221) | 51.06 (2.010) | 35.83 (1.411) | 3.91 (0.154) | 40.0 (1.575) |

See page 29 for insert arrangements and back cover for configuration sheet.



DEUTSCH HDJ Series Filter Connectors

MIL-DTL-38999 SERIES I.5

Plug Connectors

| Shell Size | A Dia. | W Thread* UNEF Class 2A |
|------------|------------------|----------------------------|
| 8 | 18.64 (0.734) | 0.4375-28 |
| 10 | 21.44 (0.844) | 0.5625-24 |
| 12 | 25.81 (1.016) | 0.6875-24 |
| 14 | 28.98 (1.141) | 0.8125-20 |
| 16 | 32.13 (1.265) | 0.9375-20 |
| 18 | 35.33 (1.391) | 1.0625-18 |
| 20 | 38.10 (1.500) | 1.1875-18 |
| 22 | 41.27 (1.625) | 1.3125-18 |
| 24 | 44.45 (1.750) | 1.4375-18 |

*UNEF Class 2A.

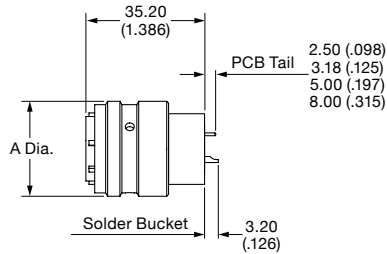

PCB/Solder Bucket Contacts

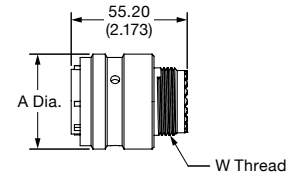

Crimp Contacts

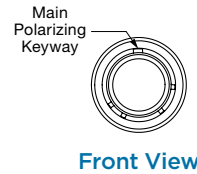

Front View

Keying Options

(Viewed from Mating Face of the Receptacle Connector)

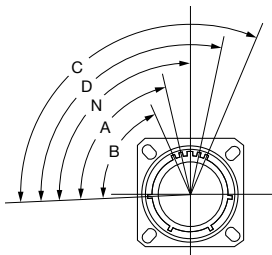

| Shell Size | Key Position | | | | |
|------------|--------------|----|----|-----|-----|
| | N | A | B | C | D |
| 9 | 95 | 77 | — | — | 113 |
| 11 | 95 | 81 | 67 | 123 | 109 |
| 13 | 95 | 75 | 63 | 127 | 115 |
| 15 | 95 | 74 | 61 | 129 | 116 |
| 17 | 95 | 77 | 65 | 125 | 113 |
| 19 | 95 | 77 | 65 | 125 | 113 |
| 21 | 95 | 77 | 65 | 125 | 113 |
| 23 | 95 | 80 | 69 | 121 | 110 |
| 25 | 95 | 80 | 69 | 121 | 110 |

See page 29 for insert arrangements and back cover for configuration sheet.



DEUTSCH H92 Series Filter Connectors

MIL-DTL-38999 SERIES II



MATING COMPATIBILITY

- MIL-DTL 38999 Series II connectors

SPACE AND WEIGHT SAVINGS

- Low profile
- Reduced weight

RELIABLE

- Positive bayonet coupling

VERSATILE

- Wide range of connector shell configurations
- Configurable filter topologies

DESIGNED FOR HARSH ENVIRONMENTS

- Vibration and shock
- Temperature extremes
- High humidity
- Altitude
- Salt spray

MIL-DTL-38999 Series II connectors are subminiature, environmental-class connectors with high and medium-density insert arrangements. They are used where a quick-disconnect coupling system is required for blind mating or other problem areas. They use the same three-point bayonet coupling method as the Series I, but feature a reduced interface length to minimize the overall length of the connector and thereby save space and weight. The reduced interface length means the connectors are not scoop proof. Available with crimp contacts, PC tails, solder cups and headers, they feature various plating options available and five keying options.

SPECIFICATIONS

Environmental

- **Temperature Range:** -55°C to 125°C
- **Physical Shock:** Typical to EIA-364-27 test condition C
- **Vibration:** Typical to EIA-364-28
- **Fungus Resistance:** Based on MIL-STD-810
- **Fluid Immersion:** Typically tested to EIA-364-10
- **Salt Spray:** Typically based on EIA/ECA-364-26
- **Humidity:** Typically EIA-364-31 test method IV
- **Durability:** 1500 cycles for Classes J and M and 500 cycles for all other connectors as per 38999 spec

Electrical

- **Grounded Line Resistance (Typ.):** 15 mΩ
- **Insulation Resistance (Typ.):** >5 GΩ
- **Dielectric Withstand (Typ.):** <5 μA
- **DWV:** up to 2000 VDC
- **Working Voltage:** up to 2000 VDC
- **Typical Test Specifications Used:**
MIL-STD-810: Test Method Standard
MIL-STD-202: Electrical & Electronic Component Parts
RTCA DO-160: Test Procedures for Airborne Equipment
EIA-364: Electrical Connector & Socket Test Procedures

Filtering

- **Capacitance Range:** 20 pF to 4 μF
- **Capacitance Tolerance:** Typically 20%
- **Unfiltered Line Cap (Typ.):** 15 pF
- **Filtering Topologies:** L, C, LC, CL, Pi, T, Double T

Transient protection available as per RTCA Publication DO 160 (see page 55).



DEUTSCH H92 Series Filter Connectors

MIL-DTL-38999 SERIES II

Jam Nut Receptacle Connectors

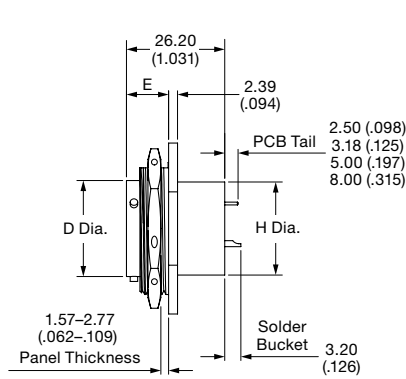

Single Flange

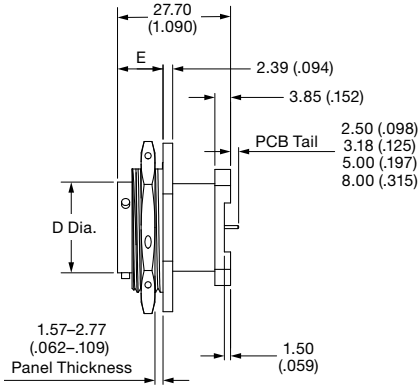

Double Flange

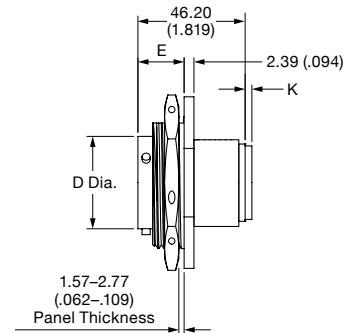

Single Flange, Crimp Contacts

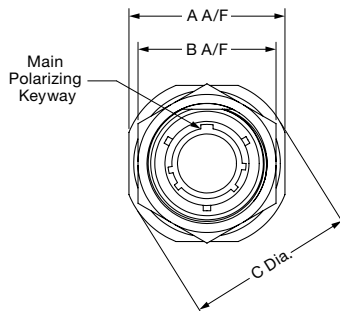

Front View

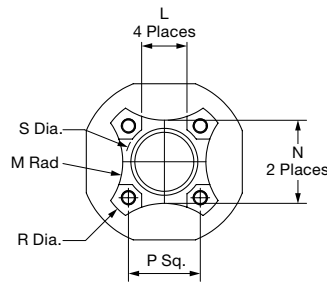

Double Flange Footprint

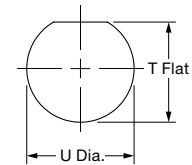

Recommended Panel Cutout

| Shell Size | A A/F | B A/F | C Dia. | D Dia. | E | H Dia. Max. | K | L Ref. | M Rad Ref. | N Ref. | P Sq. | R Dia. | S Dia. | Mounting Dims | |
|------------|------------------|------------------|------------------|------------------|------------------|------------------|-----------------|------------------|------------------|------------------|------------------|------------------|------------------|------------------|------------------|
| | | | | | | | | | | | | | | T Flat | U Dia. |
| 8 | 31.75 (1.250) | 26.97 (1.062) | 34.93 (1.375) | 12.04 (0.474) | | 15.09 (0.594) | | 8.00 (0.315) | 9.00 (0.354) | 15.50 (0.610) | 14.00 (0.551) | 27.06 (1.065) | 14.34 (0.565) | 21.08 (0.830) | 22.48 (0.885) |
| 10 | 34.93 (1.375) | 30.18 (1.188) | 38.10 (1.500) | 15.01 (0.591) | | 15.09 (0.594) | | 8.00 (0.315) | 9.00 (0.354) | 15.50 (0.610) | 14.00 (0.551) | 27.06 (1.065) | 14.34 (0.565) | 24.26 (0.955) | 25.65 (1.010) |
| 12 | 38.10 (1.500) | 33.33 (1.312) | 41.28 (1.625) | 19.08 (0.751) | | 18.26 (0.719) | | 8.00 (0.315) | 12.00 (0.472) | 18.65 (0.734) | 17.00 (0.669) | 32.06 (1.262) | 17.42 (0.686) | 27.56 (1.085) | 28.83 (1.135) |
| 14 | 41.28 (1.625) | 36.53 (1.438) | 44.45 (1.750) | 22.25 (0.876) | 11.13 (0.438) | 21.44 (0.844) | 3.05 (0.120) | 12.00 (0.472) | 18.00 (0.709) | 22.00 (0.866) | 19.00 (0.748) | 35.06 (1.380) | 20.72 (0.816) | 30.73 (1.210) | 32.01 (1.260) |
| 16 | 45.24 (1.781) | 39.68 (1.562) | 49.23 (1.938) | 25.43 (1.001) | | 24.61 (0.969) | | 12.00 (0.472) | 20.00 (0.787) | 25.25 (0.994) | 22.00 (0.866) | 39.06 (1.538) | 23.89 (0.941) | 33.91 (1.335) | 35.18 (1.385) |
| 18 | 48.01 (1.890) | 42.86 (1.688) | 51.21 (2.016) | 28.60 (1.126) | | 27.38 (1.078) | | 16.00 (0.630) | 22.00 (0.866) | 28.40 (1.118) | 25.00 (0.984) | 42.06 (1.656) | 26.43 (1.041) | 37.08 (1.460) | 38.35 (1.510) |
| 20 | 51.21 (2.016) | 46.02 (1.812) | 54.38 (2.141) | 31.77 (1.251) | | 30.56 (1.203) | | 16.00 (0.630) | 22.00 (0.866) | 31.55 (1.242) | 27.00 (1.063) | 45.06 (1.774) | 29.58 (1.165) | 40.26 (1.585) | 41.53 (1.635) |
| 22 | 54.36 (2.140) | 50.80 (2.000) | 57.53 (2.265) | 34.95 (1.376) | 11.79 (0.464) | 33.73 (1.328) | | 16.00 (0.630) | 22.00 (0.866) | 34.50 (1.358) | 29.00 (1.142) | 48.06 (1.892) | 32.76 (1.290) | 43.42 (1.709) | 44.70 (1.760) |
| 24 | 57.53 (2.265) | 53.96 (2.125) | 60.71 (2.390) | 38.13 (1.501) | | 36.91 (1.453) | 2.29 (0.090) | 16.00 (0.630) | 24.00 (0.945) | 37.30 (1.469) | 31.00 (1.221) | 51.06 (2.010) | 35.83 (1.411) | 46.61 (1.835) | 47.88 (1.885) |

See page 29 for insert arrangements and back cover for configuration sheet.



DEUTSCH H92 Series Filter Connectors

MIL-DTL-38999 SERIES II

Square Flange Receptacle Connectors

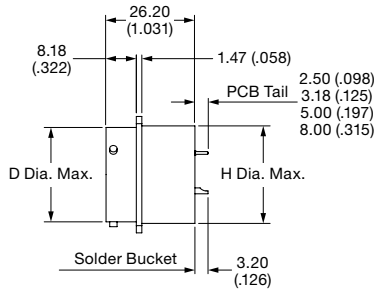

Single Flange

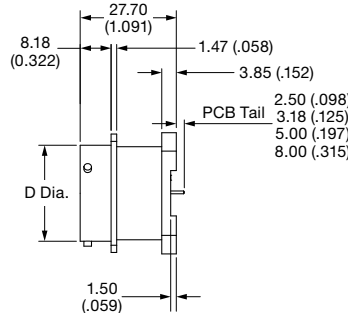

Double Flange

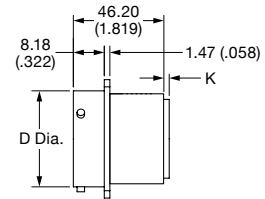

Single Flange, Crimp Contacts

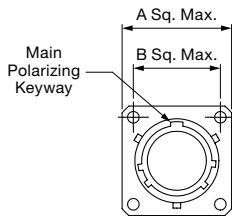

Front View

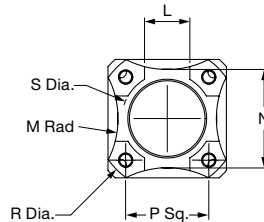

Double Flange Footprint

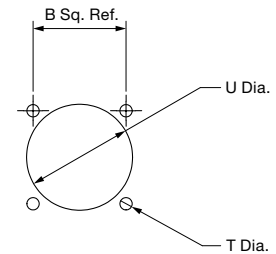

Square Flange Mounting

| Shell Size | A Sq. Max. | B Sq. | D Dia. Max. | H Dia. Max. | K | L Ref. | M Rad Ref. | N Ref. | P Sq. | R Dia. | S Dia. | Mounting Holes | |
|------------|------------------|------------------|------------------|------------------|-----------------|------------------|------------------|------------------|------------------|------------------|------------------|-----------------|------------------|
| | | | | | | | | | | | | T Dia. | U Dia. Min. |
| 8 | 21.03 (0.828) | 15.09 (0.594) | 12.04 (0.474) | 15.09 (0.594) | | 8.00 (0.315) | 9.00 (0.354) | 15.50 (0.610) | 14.00 (0.551) | 27.06 (1.065) | 14.34 (0.565) | | 14.15 (0.557) |
| 10 | 24.23 (0.954) | 18.26 (0.719) | 15.01 (0.591) | 15.09 (0.594) | | 8.00 (0.315) | 9.00 (0.354) | 15.50 (0.610) | 14.00 (0.551) | 27.06 (1.065) | 14.34 (0.565) | | 17.32 (0.682) |
| 12 | 26.59 (1.047) | 20.62 (0.812) | 19.08 (0.751) | 18.26 (0.719) | | 8.00 (0.315) | 12.00 (0.472) | 18.65 (0.734) | 17.00 (0.669) | 32.06 (1.262) | 17.42 (0.686) | | 21.69 (0.854) |
| 14 | 28.98 (1.141) | 23.01 (0.906) | 22.25 (0.876) | 21.44 (0.844) | 3.05 (0.120) | 12.00 (0.472) | 18.00 (0.709) | 22.00 (0.866) | 19.00 (0.748) | 35.06 (1.380) | 20.72 (0.816) | 3.25 (0.128) | 24.87 (0.979) |
| 16 | 31.34 (1.234) | 24.61 (0.969) | 25.43 (1.001) | 24.61 (0.969) | | 12.00 (0.472) | 20.00 (0.787) | 25.25 (0.994) | 22.00 (0.866) | 39.06 (1.538) | 23.89 (0.941) | | 28.04 (1.104) |
| 18 | 33.73 (1.328) | 26.97 (1.062) | 28.60 (1.126) | 27.38 (1.078) | | 16.00 (0.630) | 22.00 (0.866) | 28.40 (1.118) | 25.00 (0.984) | 42.06 (1.656) | 26.43 (1.041) | | 31.22 (1.229) |
| 20 | 36.91 (1.453) | 29.36 (1.156) | 31.77 (1.251) | 30.56 (1.203) | | 16.00 (0.630) | 22.00 (0.866) | 31.55 (1.242) | 27.00 (1.063) | 45.06 (1.774) | 29.58 (1.165) | | 34.39 (1.354) |
| 22 | 40.08 (1.578) | 31.75 (1.250) | 34.95 (1.376) | 33.73 (1.328) | | 16.00 (0.630) | 22.00 (0.866) | 34.50 (1.358) | 29.00 (1.142) | 48.06 (1.892) | 32.76 (1.290) | 3.91 (0.154) | 37.57 (1.479) |
| 24 | 43.26 (1.703) | 34.93 (1.375) | 38.13 (1.501) | 36.91 (1.453) | 2.29 (0.090) | 16.00 (0.630) | 24.00 (0.945) | 37.30 (1.469) | 31.00 (1.221) | 51.06 (2.010) | 35.83 (1.411) | 3.81 (0.150) | 40.74 (1.604) |

See page 29 for insert arrangements and back cover for configuration sheet.



DEUTSCH H92 Series Filter Connectors

MIL-DTL-38999 SERIES II

Plug Connectors

| Shell Size | A Dia. Max. | K Max. | Y Thread* |
|------------|---------------|--------------|-------------|
| 8 | 17.75 (0.699) | | 0.4375 - 28 |
| 10 | 21.05 (0.829) | | 0.5625 - 24 |
| 12 | 24.60 (0.969) | | 0.6875 - 24 |
| 14 | 28.05 (1.104) | 3.05 (0.120) | 0.8125 - 20 |
| 16 | 31.10 (1.224) | | 0.9375 - 20 |
| 18 | 34.40 (1.354) | | 1.0625 - 18 |
| 20 | 37.65 (1.482) | | 1.1875 - 18 |
| 22 | 40.90 (1.610) | | 1.3125 - 18 |
| 24 | 44.10 (1.736) | 2.29 (0.090) | 1.4375 - 18 |

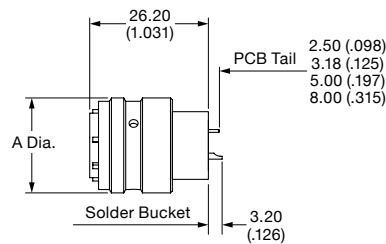

PCB/Solder Bucket Contacts

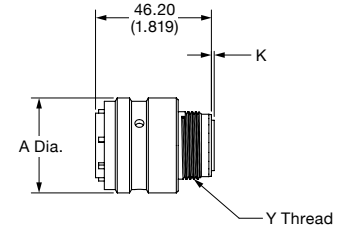

Crimp Contacts

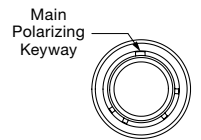

Front View

Keying Options

(Viewed from Mating Face of the Receptacle Connector)

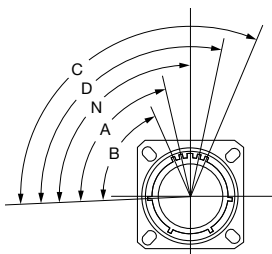

| Shell Size | Key Position | | | | |
|------------|--------------|----|----|-----|-----|
| | N | A | B | C | D |
| 9 | 95 | 77 | — | — | 113 |
| 11 | 95 | 81 | 67 | 123 | 109 |
| 13 | 95 | 75 | 63 | 127 | 115 |
| 15 | 95 | 74 | 61 | 129 | 116 |
| 17 | 95 | 77 | 65 | 125 | 113 |
| 19 | 95 | 77 | 65 | 125 | 113 |
| 21 | 95 | 77 | 65 | 125 | 113 |
| 23 | 95 | 80 | 69 | 121 | 110 |
| 25 | 95 | 80 | 69 | 121 | 110 |

See page 29 for insert arrangements and back cover for configuration sheet.



DEUTSCH H93 Series Filter Connectors

MIL-DTL-38999 SERIES III



MIL-DTL-38999 Series III connectors are subminiature, environmental-class connectors with high and medium-density insert arrangements. The triple-start threaded interface makes them well suited to high-vibration and high-shock applications. Available with crimp contacts, PC tails, solder cups and headers, they feature various plating options available and five keying options.

SPECIFICATIONS

Environmental

- **Temperature Range:** -55°C to 125°C
- **Physical Shock:** Typical to EIA-364-27 test condition C
- **Vibration:** Typical to EIA-364-28
- **Fungus Resistance:** Based on MIL-STD-810
- **Fluid Immersion:** Typically tested to EIA-364-10
- **Salt Spray:** Typically based on EIA/ECA-364-26
- **Humidity:** Typically EIA-364-31 test method IV
- **Durability:** 1500 cycles for Classes J and M and 500 cycles for all other connectors as per 38999 spec

Electrical

- **Grounded Line Resistance (Typ.):** 15 mΩ
- **Insulation Resistance (Typ.):** >5 GΩ
- **Dielectric Withstand (Typ.):** <5 μA
- **DWV:** up to 2000 VDC
- **Working Voltage:** up to 2000 VDC
- **Typical Test Specifications Used:**
 - Mil-STD-810: Test Method Standard
 - Mil-STD-202: Electrical & Electronic Component Parts
 - RTCA DO-160: Test Procedures for Airborne Equipment
 - EIA-364: Electrical Connector & Socket Test Procedures

Filtering Capabilities

- **Capacitance Range:** 20 pF to 4 μF
- **Capacitance Tolerance:** Typically 20%
- **Unfiltered Line Capacitance (Typ.):** 15 pF
- **Filtering Topologies Available:** L, C, LC, CL, Pi, T, Double T

Transient protection available as per RTCA Publication DO 160 (see page 55).

MATING COMPATIBILITY

- MIL-DTL-38999 Series III connectors
- DEUTSCH DTS Series connectors
- DEUTSCH ACT Series composite connectors

RELIABLE

- Triple-start, self-locking threaded coupling mechanism
- 100% scoop proof design
- RFI shell-to-shell continuity

VERSATILE

- Wide range of connector shell configurations
- Configurable filter topologies

DESIGNED FOR HARSH ENVIRONMENTS

- Vibration and shock
- Temperature extremes
- High humidity
- Altitude
- Salt spray



DEUTSCH H93 Series Filter Connectors

MIL-DTL-38999 SERIES III

Jam Nut Receptacles

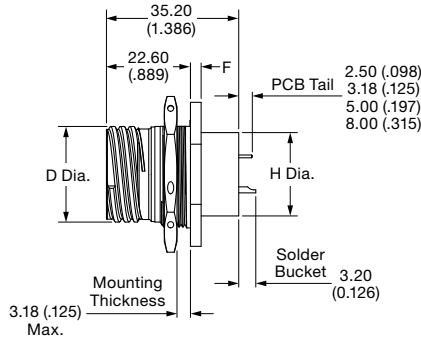

Single Flange

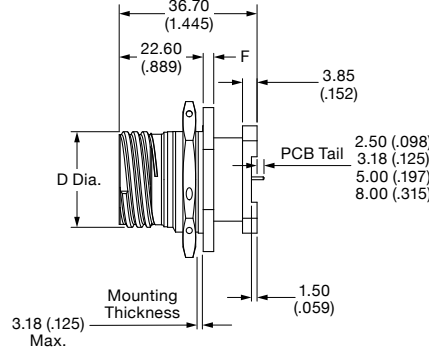

Double Flange

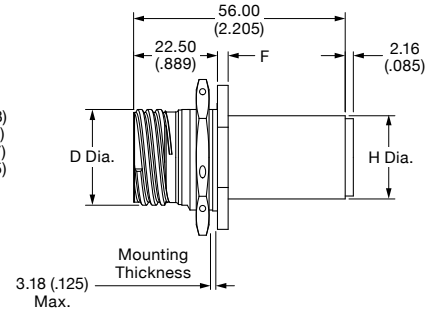

Single Flange, Crimp Contacts

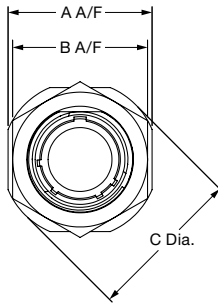

Front View

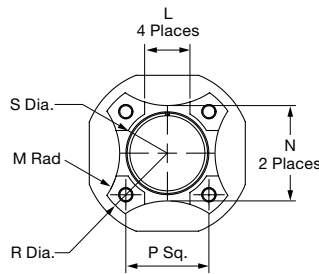

Double Flange Footprint

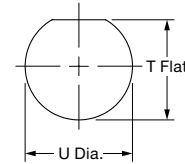

Recommended Panel Cutout

| Shell Size | A A/F | B A/F Max. | C Dia. | D Dia. | F | H Dia. Max. | L Ref. | M Rad Ref. | N Ref. | P Sq. | R Dia. | S Dia. | Mounting Dims | |
|------------|------------------|------------------|------------------|-------------------|-----------------|------------------|------------------|------------------|------------------|------------------|------------------|------------------|------------------|------------------|
| | | | | | | | | | | | | | T Flat | U Dia. |
| 9 | 27.00 (1.063) | 24.00 (0.945) | 30.20 (1.189) | 15.88 (0.625) | | 15.67 (0.616) | 8.00 (0.315) | 9.00 (0.354) | 15.50 (0.610) | 14.00 (0.551) | 27.06 (1.065) | 14.34 (0.565) | 17.02 (0.670) | 17.78 (0.700) |
| 11 | 31.80 (1.252) | 27.00 (1.063) | 34.90 (1.374) | 19.05 (0.750) | | 15.67 (0.616) | 8.00 (0.315) | 9.00 (0.354) | 15.50 (0.610) | 14.00 (0.551) | 27.06 (1.065) | 14.34 (0.565) | 19.59 (0.771) | 20.96 (0.825) |
| 13 | 34.90 (1.374) | 32.00 (1.260) | 38.10 (1.500) | 22.23 (0.875) | 2.20 (0.087) | 18.85 (0.742) | 8.00 (0.315) | 12.00 (0.472) | 18.65 (0.734) | 17.00 (0.669) | 32.06 (1.262) | 17.42 (0.686) | 24.26 (0.955) | 25.65 (1.010) |
| 15 | 38.10 (1.500) | 36.00 (1.417) | 41.30 (1.626) | 25.40 (1.000) | | 22.22 (0.874) | 12.00 (0.472) | 18.00 (0.709) | 22.00 (0.866) | 19.00 (0.748) | 35.06 (1.380) | 20.72 (0.816) | 27.56 (1.085) | 28.83 (1.135) |
| 17 | 41.30 (1.626) | 37.00 (1.457) | 44.50 (1.752) | 30.16 (1.1875) | | 25.45 (1.001) | 12.00 (0.472) | 20.00 (0.787) | 25.25 (0.994) | 22.00 (0.866) | 39.06 (1.538) | 23.89 (0.941) | 30.73 (1.210) | 32.01 (1.260) |
| 19 | 46.00 (1.811) | 41.00 (1.614) | 49.20 (1.937) | 31.75 (1.250) | | 28.57 (1.125) | 16.00 (0.630) | 22.00 (0.866) | 28.40 (1.118) | 25.00 (0.984) | 42.06 (1.656) | 26.43 (1.041) | 33.91 (1.335) | 35.18 (1.385) |
| 21 | 49.20 (1.937) | 46.00 (1.811) | 52.40 (2.063) | 34.93 (1.375) | | 31.75 (1.250) | 16.00 (0.630) | 22.00 (0.866) | 31.55 (1.242) | 27.00 (1.063) | 45.06 (1.774) | 29.58 (1.165) | 37.08 (1.460) | 38.35 (1.510) |
| 23 | 52.40 (2.063) | 50.00 (1.969) | 55.60 (2.189) | 38.10 (1.500) | 3.00 (0.118) | 34.72 (1.367) | 16.00 (0.630) | 22.00 (0.866) | 34.50 (1.358) | 29.00 (1.142) | 48.06 (1.892) | 32.76 (1.290) | 40.26 (1.585) | 41.53 (1.635) |
| 25 | 55.60 (2.189) | 51.23 (2.017) | 58.70 (2.311) | 41.28 (1.625) | | 37.5 (1.476) | 16.00 (0.630) | 24.00 (0.945) | 37.30 (1.469) | 31.00 (1.221) | 51.06 (2.010) | 35.83 (1.411) | 43.43 (1.710) | 44.70 (1.760) |

See page 29 for insert arrangements and back cover for configuration sheet.



DEUTSCH H93 Series Filter Connectors

MIL-DTL-38999 SERIES III

Square Flange Receptacle Connectors

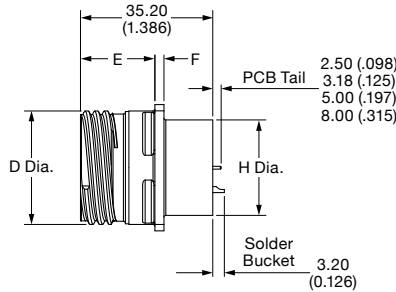

Single Flange

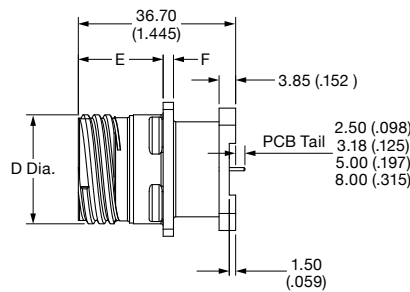

Double Flange

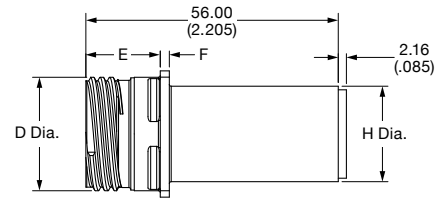

Single Flange, Crimp Contacts

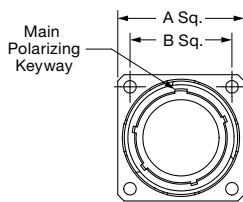

Front View

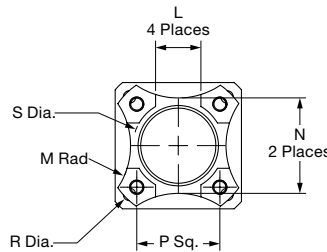

Double Flange Footprint

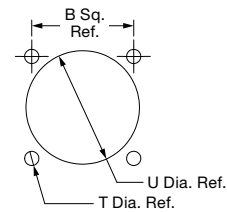

Square Flange Mounting

Shell Dimensions

| Shell Size | A Sq. | B Sq. | D Dia. | E Max. | F Max. | H Dia. Max. | L Ref. | M Rad Ref. | N Ref. | P Sq. | R Dia. | S Dia. | Mounting Holes | |
|------------|------------------|------------------|-------------------|------------------|-----------------|------------------|------------------|------------------|------------------|------------------|------------------|------------------|-----------------|------------------|
| | | | | | | | | | | | | | T Dia. | U Dia. Min. |
| 9 | 23.80 (0.937) | 18.26 (0.719) | 15.88 (0.625) | | | 15.67 (0.616) | 8.00 (0.315) | 9.00 (0.354) | 15.50 (0.610) | 14.00 (0.551) | 27.06 (1.065) | 14.34 (0.565) | | 16.66 (0.656) |
| 11 | 26.19 (1.031) | 20.62 (0.812) | 19.05 (0.750) | | | 15.67 (0.616) | 8.00 (0.315) | 9.00 (0.354) | 15.50 (0.610) | 14.00 (0.551) | 27.06 (1.065) | 14.34 (0.565) | | 20.22 (0.796) |
| 13 | 28.60 (1.126) | 23.01 (0.906) | 22.23 (0.875) | 20.88 (0.822) | 2.50 (0.098) | 18.85 (0.742) | 8.00 (0.315) | 12.00 (0.472) | 18.65 (0.734) | 17.00 (0.669) | 32.06 (1.262) | 17.42 (0.686) | | 23.42 (0.922) |
| 15 | 30.99 (1.220) | 24.61 (0.969) | 25.40 (1.000) | | | 22.22 (0.874) | 12.00 (0.472) | 18.00 (0.709) | 22.00 (0.866) | 19.00 (0.748) | 35.06 (1.380) | 20.72 (0.816) | | 3.25 (0.128) |
| 17 | 33.30 (1.311) | 26.97 (1.062) | 30.16 (1.1875) | | | 25.45 (1.001) | 12.00 (0.472) | 20.00 (0.787) | 25.25 (0.994) | 22.00 (0.866) | 39.06 (1.538) | 23.89 (0.941) | | 30.96 (1.219) |
| 19 | 36.50 (1.437) | 29.36 (1.156) | 31.75 (1.250) | | | 28.57 (1.125) | 16.00 (0.630) | 22.00 (0.866) | 28.40 (1.118) | 25.00 (0.984) | 42.06 (1.656) | 26.43 (1.041) | | 32.94 (1.297) |
| 21 | 39.70 (1.563) | 31.75 (1.250) | 34.93 (1.375) | | | 31.75 (1.250) | 16.00 (0.630) | 22.00 (0.866) | 31.55 (1.242) | 27.00 (1.063) | 45.06 (1.774) | 29.58 (1.165) | | 36.12 (1.422) |
| 23 | 42.90 (1.689) | 34.93 (1.375) | 38.10 (1.500) | 20.09 (0.791) | 3.20 (0.126) | 34.72 (1.367) | 16.00 (0.630) | 22.00 (0.866) | 34.50 (1.358) | 29.00 (1.142) | 48.06 (1.892) | 32.76 (1.290) | | 39.29 (1.547) |
| 25 | 46.00 (1.811) | 38.1 (1.500) | 41.28 (1.625) | | | 37.50 (1.476) | 16.00 (0.630) | 24.00 (0.945) | 37.30 (1.469) | 31.00 (1.221) | 51.06 (2.010) | 35.83 (1.411) | 3.91 (0.154) | 42.47 (1.672) |

See page 29 for insert arrangements and back cover for configuration sheet.



DEUTSCH H93 Series Filter Connectors

MIL-DTL-38999 SERIES III

Plug Connectors

| Shell Size | A Dia. Max. | V Thread (0-6g 0.100R) |
|------------|------------------|---------------------------|
| 9 | 21.80 (0.858) | M12 x 1 |
| 11 | 25.0 (0.984) | M15 x 1 |
| 13 | 29.40 (1.157) | M18 x 1 |
| 15 | 32.50 (1.270) | M22 x 1 |
| 17 | 35.70 (1.400) | M25 x 1 |
| 19 | 38.50 (1.510) | M28 x 1 |
| 21 | 41.70 (1.640) | M31 x 1 |
| 23 | 44.90 (1.760) | M34 x 1 |
| 25 | 48.00 (1.880) | M37 x 1 |

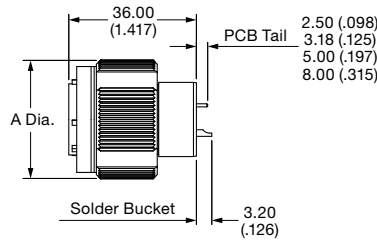

PCB/Solder Bucket Contacts

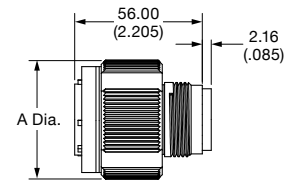

Crimp Contacts

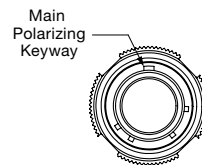

Front View

Keying Options

(Viewed from Mating Face of the Receptacle Connector)

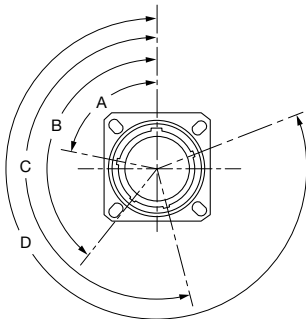

| Shell Size | Key Position | Polarization (Degrees) | | | |
|--------------------|--------------|------------------------|-----|-----|-----|
| | | A | B | C | D |
| 09 | N | 105 | 140 | 215 | 265 |
| | A | 102 | 132 | 248 | 320 |
| | B | 80 | 118 | 230 | 312 |
| | C | 35 | 140 | 205 | 275 |
| | D | 64 | 155 | 234 | 304 |
| 11, 13, 15 | E | 91 | 131 | 197 | 240 |
| | N | 95 | 141 | 208 | 236 |
| | A | 113 | 156 | 182 | 292 |
| | B | 90 | 145 | 195 | 252 |
| | C | 53 | 156 | 220 | 255 |
| 17, 19, 21, 23, 25 | D | 119 | 146 | 176 | 298 |
| | E | 51 | 141 | 184 | 242 |
| | N | 80 | 142 | 196 | 293 |
| | A | 135 | 170 | 200 | 310 |
| | B | 49 | 169 | 200 | 244 |
| | C | 66 | 140 | 200 | 257 |
| | D | 62 | 145 | 180 | 280 |
| | E | 79 | 153 | 197 | 272 |

See page 29 for insert arrangements and back cover for configuration sheet.



DEUTSCH H94 Series Filter Connectors

MIL-DTL-38999 SERIES IV



MIL-DTL-38999 Series IV connectors are subminiature, environmental-class connectors with high and medium-density insert arrangements. The breech lock coupling mechanism, which requires 1/4 turn for mating, makes them well suited for blind mating and high-vibration applications. Available with crimp contacts, PC tails, solder cups and headers, they feature various plating options available and five keying options.

SPECIFICATIONS

MATING COMPATIBILITY

- MIL-DTL-38999 connectors
- DEUTSCH DIV connectors

RELIABLE

- Breech lock coupling, one-quarter turn
- 100% scoop proof
- RFI shell-to-shell continuity

VERSATILE

- Wide range of connector shell configurations
- Configurable filter topologies

DESIGNED FOR HARSH ENVIRONMENTS

- Vibration and shock
- Temperature extremes
- High humidity
- Altitude
- Salt spray

Environmental

- **Temperature Range:** -55°C to 125°C
- **Physical Shock:** Typical to EIA-364-27 test condition C
- **Vibration:** Typical to EIA-364-28
- **Fungus Resistance:** Based on MIL-STD-810
- **Fluid Immersion:** Typically tested to EIA-364-10
- **Salt Spray:** Typically based on EIA/ECA-364-26
- **Humidity:** Typically EIA-364-31 test method IV
- **Durability:** 1500 cycles for Classes J and M and 500 cycles for all other connectors as per 38999 spec

Electrical

- **Grounded Line Resistance (Typ.):** 15 mΩ
- **Insulation Resistance (Typ.):** >5 GΩ
- **Dielectric Withstand (Typ.):** <5 μA
- **DWV:** up to 2000 VDC
- **Working Voltage:** up to 2000 VDC
- **Typical Test Specifications Used:**
MIL-STD-810: Test Method Standard
MIL-STD-202: Electrical & Electronic Component Parts
RTCA DO-160: Test Procedures for Airborne Equipment
EIA-364: Electrical Connector & Socket Test Procedures

Filtering

- **Capacitance Range:** 20 pF to 4 μF
- **Capacitance Tolerance:** Typically 20%
- **Unfiltered Line Cap (Typ.):** 15 pF
- **Filtering Topologies:** L, C, LC, CL, Pi, T, Double T

Transient protection available as per RTCA Publication DO 160 (see page 55).



DEUTSCH H94 Series Filter Connectors

MIL-DTL-38999 SERIES IV

Jam Nut Receptacle Connectors

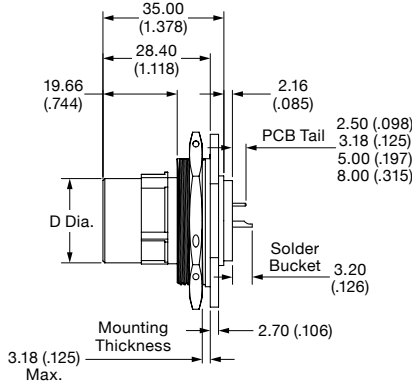

Single Flange

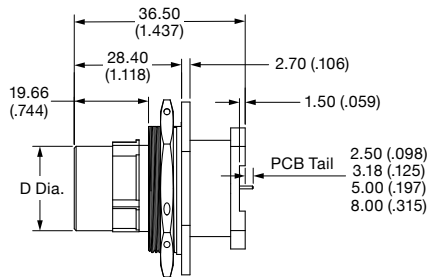

Double Flange

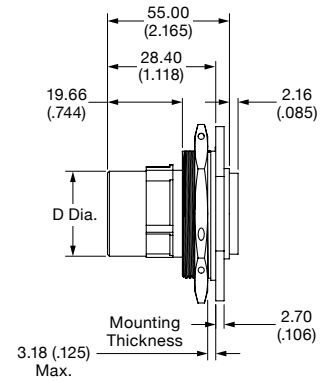

Single Flange, Crimp Contacts

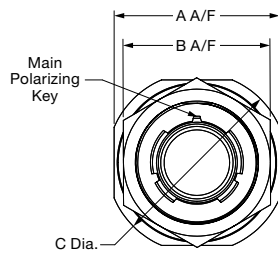

Front View

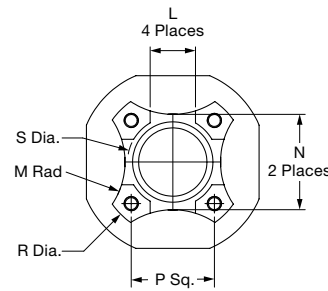

Double Flange Footprint

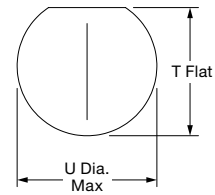

Recommended Panel Cutout

| Shell Size | A A/F Max. | B A/F Max. | C Dia. Max. | D Dia. Max. | L Ref. | M Rad Ref. | N Ref. | P Sq. | R Dia. | S Dia. | Mounting Dims | |
|------------|------------------|------------------|------------------|------------------|------------------|------------------|------------------|------------------|------------------|------------------|------------------|------------------|
| | | | | | | | | | | | T Flat | U Dia. |
| 11 | 35.40 (1.394) | 32.00 (1.260) | 38.60 (1.520) | 12.93 (0.509) | 8.00 (0.315) | 9.00 (0.354) | 15.50 (0.610) | 14.00 (0.551) | 27.06 (1.065) | 14.34 (0.565) | 24.26 (0.955) | 25.65 (1.010) |
| 13 | 38.60 (1.520) | 36.00 (1.417) | 41.70 (1.642) | 16.10 (0.634) | 8.00 (0.315) | 12.00 (0.472) | 18.65 (0.734) | 17.00 (0.669) | 32.06 (1.262) | 17.42 (0.686) | 27.56 (1.085) | 28.83 (1.135) |
| 15 | 41.70 (1.642) | 41.00 (1.614) | 44.90 (1.768) | 19.28 (0.759) | 12.00 (0.472) | 18.00 (0.709) | 22.00 (0.866) | 19.00 (0.748) | 35.06 (1.380) | 20.72 (0.816) | 30.73 (1.210) | 32.01 (1.260) |
| 17 | 45.70 (1.799) | 41.00 (1.614) | 49.70 (1.957) | 22.48 (0.885) | 12.00 (0.472) | 20.00 (0.787) | 25.25 (0.994) | 22.00 (0.866) | 39.06 (1.538) | 23.89 (0.941) | 33.91 (1.335) | 35.18 (1.385) |
| 19 | 48.50 (1.909) | 46.00 (1.811) | 51.70 (2.035) | 25.63 (1.009) | 16.00 (0.630) | 22.00 (0.866) | 28.40 (1.118) | 25.00 (0.984) | 42.06 (1.656) | 26.43 (1.041) | 37.08 (1.460) | 38.35 (1.510) |
| 21 | 51.70 (2.035) | 50.00 (1.968) | 54.80 (2.157) | 28.80 (1.134) | 16.00 (0.630) | 22.00 (0.866) | 31.55 (1.242) | 27.00 (1.063) | 45.06 (1.774) | 29.58 (1.165) | 40.26 (1.585) | 41.53 (1.635) |
| 23 | 54.80 (2.157) | 50.00 (1.968) | 58.00 (2.283) | 31.98 (1.259) | 16.00 (0.630) | 22.00 (0.866) | 34.50 (1.358) | 29.00 (1.142) | 48.06 (1.892) | 32.76 (1.290) | 43.42 (1.709) | 44.70 (1.760) |
| 25 | 58.00 (2.283) | 55.00 (2.165) | 61.20 (2.409) | 35.15 (1.384) | 16.00 (0.630) | 24.00 (0.945) | 37.30 (1.469) | 31.00 (1.221) | 51.06 (2.010) | 35.83 (1.411) | 46.61 (1.835) | 47.88 (1.885) |

See page 29 for insert arrangements and back cover for configuration sheet.



DEUTSCH H94 Series Filter Connectors

MIL-DTL-38999 SERIES IV

Square Flange Receptacle Connectors

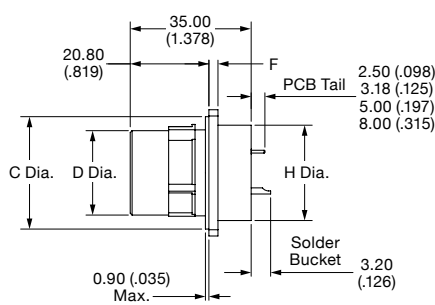

Single Flange

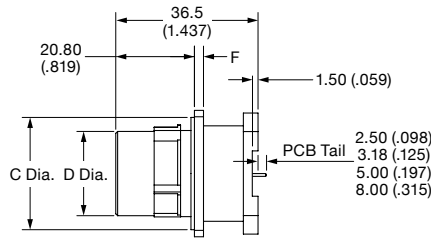

Double Flange

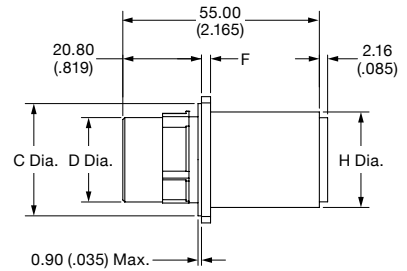

Single Flange, Crimp Contacts

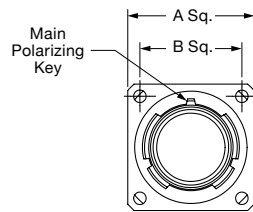

Front View

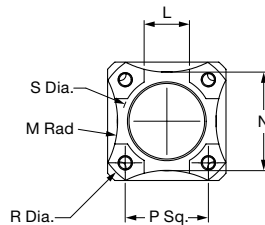

Double Flange Footprint

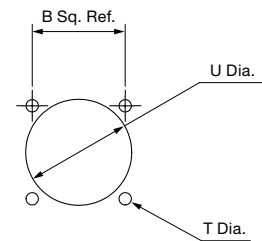

Square Flange Mounting

| Shell Size | A Sq. Max. | B Sq. | C Dia. Max. | D Dia. Max. | F Max. | H Dia. Max. | L Ref. | M Rad Ref. | N Ref. | P Sq. | R Dia. | S Dia. | Mounting Holes | |
|------------|------------------|------------------|------------------|------------------|-----------------|------------------|------------------|------------------|------------------|------------------|------------------|------------------|-----------------|------------------|
| | | | | | | | | | | | | | T Dia. | U Dia. Min. |
| 11 | 26.70 (1.051) | 20.62 (0.812) | 20.15 (0.793) | 12.93 (0.509) | | 15.67 (0.616) | 8.00 (0.315) | 9.00 (0.354) | 15.50 (0.610) | 14.00 (0.551) | 27.06 (1.065) | 14.34 (0.565) | | 20.22 (0.796) |
| 13 | 29.10 (1.146) | 23.02 (0.906) | 23.35 (0.919) | 16.10 (0.634) | | 18.85 (0.742) | 8.00 (0.315) | 12.00 (0.472) | 18.65 (0.734) | 17.00 (0.669) | 32.06 (1.262) | 17.42 (0.686) | | 23.42 (0.922) |
| 15 | 31.50 (1.240) | 24.62 (0.970) | 26.52 (1.044) | 19.28 (0.759) | 2.60 (0.102) | 22.22 (0.874) | 12.00 (0.472) | 18.00 (0.709) | 22.00 (0.866) | 19.00 (0.748) | 35.06 (1.380) | 20.72 (0.816) | 3.25 (0.128) | 26.59 (1.047) |
| 17 | 33.90 (1.335) | 26.98 (1.062) | 29.72 (1.170) | 22.48 (0.885) | | 25.45 (1.001) | 12.00 (0.472) | 20.00 (0.787) | 25.25 (0.994) | 22.00 (0.866) | 39.06 (1.538) | 23.89 (0.941) | | 30.96 (1.219) |
| 19 | 37.10 (1.461) | 29.36 (1.156) | 32.87 (1.294) | 25.63 (1.009) | | 28.57 (1.125) | 16.00 (0.630) | 22.00 (0.866) | 28.40 (1.118) | 25.00 (0.984) | 42.06 (1.656) | 26.43 (1.041) | | 32.94 (1.297) |
| 21 | 40.20 (1.583) | 31.76 (1.250) | 36.05 (1.419) | 28.80 (1.134) | | 31.75 (1.250) | 16.00 (0.630) | 22.00 (0.866) | 31.55 (1.242) | 27.00 (1.063) | 45.06 (1.774) | 29.58 (1.165) | | 36.12 (1.422) |
| 23 | 43.40 (1.709) | 34.92 (1.374) | 39.22 (1.544) | 31.98 (1.259) | 3.40 (0.134) | 34.72 (1.367) | 16.00 (0.630) | 22.00 (0.866) | 34.50 (1.358) | 29.00 (1.142) | 48.06 (1.892) | 32.76 (1.290) | 3.91 (0.154) | 39.29 (1.547) |
| 25 | 46.60 (1.835) | 38.10 (1.500) | 42.40 (1.669) | 35.15 (1.384) | | 37.5 (1.476) | 16.00 (0.630) | 24.00 (0.945) | 37.30 (1.469) | 31.00 (1.221) | 51.06 (2.010) | 35.83 (1.411) | | 42.47 (1.672) |

See page 29 for insert arrangements and back cover for configuration sheet.



DEUTSCH H94 Series Filter Connectors

MIL-DTL-38999 SERIES IV

Plug Connectors

| Shell Size | A Dia. Max | B Dia. Max | V Thread (0-6g 0.100R) |
|------------|----------------|---------------|------------------------|
| 11 | 26.60 (1.047) | 19.70 (0.775) | M15 x 1.0 |
| 13 | 31.00 (1.220) | 22.90 (0.901) | M18 x 1.0 |
| 15 | 34.20 (1.346) | 26.40 (1.039) | M22 x 1.0 |
| 17 | 37.40 (1.472) | 29.2 (1.149) | M25 x 1.0 |
| 19 | 40.20 (1.583) | 32.4 (1.275) | M28 x 1.0 |
| 21 | 43.30 (1.704) | 35.60 (1.401) | M31 x 1.0 |
| 23 | 46.50 (1.831) | 38.8 (1.527) | M34 x 1.0 |
| 25 | 49.700 (1.957) | 41.90 (1.649) | M37 x 1.0 |

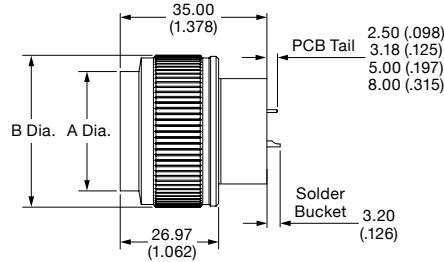

PCB/Solder Bucket Contacts

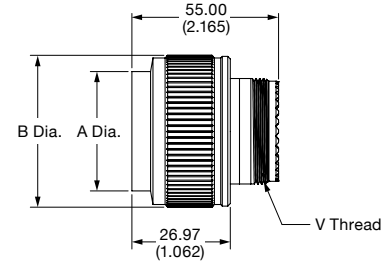

Crimp Contacts

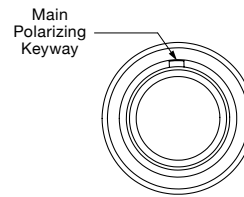

Front View

Keying Options

(Viewed from Mating Face of the Receptacle Connector)

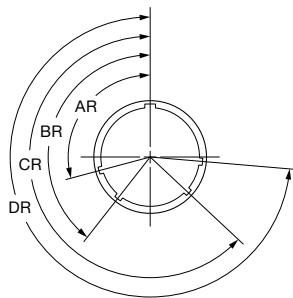

| Shell Size | Key Position | Polarization (Degrees) | | | |
|------------|--------------|------------------------|-----|-----|-----|
| | | AR | BR | CR | DR |
| 9 | N | 105 | 140 | 215 | 265 |
| | A | 102 | 132 | 248 | 320 |
| | B | 80 | 118 | 230 | 312 |
| | C | 35 | 140 | 205 | 275 |
| | D | 64 | 155 | 234 | 304 |
| 11, 13, 15 | E | 91 | 131 | 197 | 240 |
| | N | 95 | 141 | 208 | 236 |
| | A | 113 | 156 | 182 | 292 |
| | B | 90 | 145 | 195 | 252 |
| | C | 53 | 156 | 220 | 255 |
| 17, 19 | D | 119 | 146 | 176 | 298 |
| | E | 51 | 141 | 184 | 242 |
| | N | 80 | 142 | 196 | 293 |
| | A | 135 | 170 | 200 | 310 |
| | B | 49 | 169 | 200 | 244 |
| 21, 23, 25 | C | 66 | 140 | 200 | 257 |
| | D | 62 | 145 | 180 | 280 |
| | E | 79 | 153 | 197 | 272 |
| | N | 80 | 142 | 196 | 293 |
| | A | 135 | 170 | 200 | 310 |
| 21, 23, 25 | B | 49 | 169 | 200 | 244 |
| | C | 66 | 140 | 200 | 257 |
| | D | 62 | 145 | 180 | 280 |
| | E | 79 | 153 | 197 | 272 |

See page 29 for insert arrangements and back cover for configuration sheet.



DEUTSCH AS Series Filter Connectors



DEUTSCH AS Series connectors are based on MIL-DTL-38999 Series I coupling interface lengths and Series II diameters. They have an elliptical flange. With high and medium-density insert arrangements, the environmental-class plugs and receptacles are used where a quick-disconnect coupling system is required for blind mating or other problem areas. Available with crimp contacts, PC tails, solder cups and headers, they feature various plating options available and five keying options. The three-point bayonet coupling requires 1/3 turn for full mating.

MATING COMPATIBILITY

- MIL-DTL-38999 Series 1.5 connectors
- DEUTSCH HDJ and AS Series connectors
- JN1003 connectors

SPACE AND WEIGHT SAVINGS

- Reduced mass

RELIABLE

- 100% scoop proof
- Positive bayonet coupling
- RFI shell-to-shell continuity

VERSATILE

- Wide range of connector shell configurations
- Configurable filter topologies

DESIGNED FOR HARSH ENVIRONMENTS

- Vibration and shock
- Temperature extremes
- High humidity
- Altitude
- Salt spray

SPECIFICATIONS

Environmental

- **Temperature Range:** -55°C to 125°C
- **Physical Shock:** Typical to EIA-364-27 test condition C
- **Vibration:** Typical to EIA-364-28
- **Fungus Resistance:** Based on MIL-STD-810
- **Fluid Immersion:** Typically tested to EIA-364-10
- **Salt Spray:** Typically based on EIA/ECA-364-26
- **Humidity:** Typically EIA-364-31 test method IV
- **Durability:** 1500 cycles for Classes J and M and 500 cycles for all other connectors as per 38999 spec

Electrical

- **Grounded Line Resistance (Typ.):** 15 mΩ
- **Insulation Resistance (Typ.):** >5 GΩ
- **Dielectric Withstand (Typ.):** <5 mA
- **DWV:** up to 2000 VDC
- **Working Voltage:** up to 2000 VDC
- **Typical Test Specifications Used:**
MIL-STD-810: Test Method Standard
MIL-STD-202: Electrical & Electronic Component Parts
RTCA DO-160: Test Procedures for Airborne Equipment
EIA-364: Electrical Connector & Socket Test Procedures

Filtering

- **Capacitance Range:** 20 pF to 4 μF
- **Capacitance Tolerance:** Typically 20%
- **Unfiltered Line Cap (Typ.):** 15 pF
- **Filtering Topologies:** L, C, LC, CL, Pi, T, Double T

Transient protection available as per RTCA Publication DO 160 (see page 55).



DEUTSCH AS Series Filter Connectors

Jam Nut Receptacles

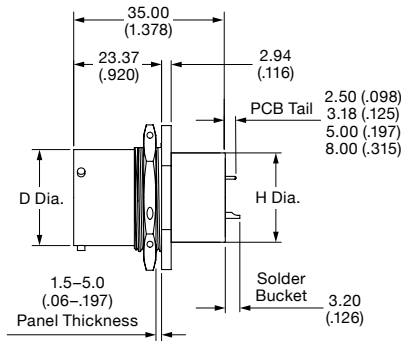

Single Flange

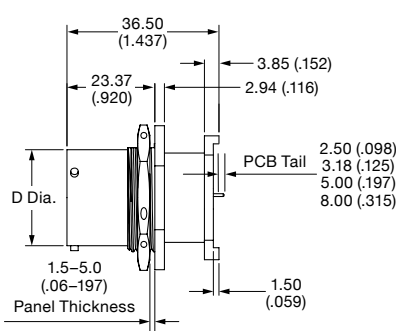

Double Flange

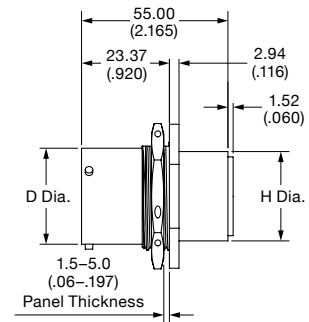

Single Flange, Crimp Contacts

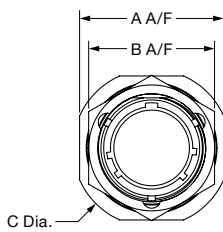

Front View

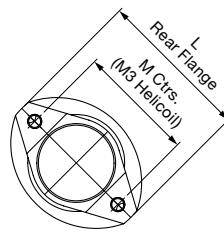

Double Flange Footprint

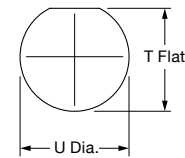

Recommended Panel Cutout

| Shell Size | A A/F | B A/F | C Dia. Max. | D Dia. Max. | H Dia. Max. | L Max. | M | Mounting Dims | |
|------------|------------------|------------------|------------------|------------------|------------------|------------------|------------------|------------------|------------------|
| | | | | | | | | T Flat | U Dia. |
| 8 | 23.83 (0.938) | 19.05 (0.750) | 27.38 (1.078) | 12.04 (0.474) | 11.07 (0.436) | 27.50 (1.083) | 19.80 (0.779) | 13.62 (0.536) | 14.53 (0.572) |
| 10 | 26.97 (1.061) | 22.22 (0.875) | 30.56 (1.203) | 15.01 (0.591) | 14.24 (0.561) | 32.00 (1.260) | 19.80 (0.779) | 16.79 (0.661) | 17.70 (0.697) |
| 12 | 31.75 (1.250) | 26.97 (1.062) | 35.33 (1.391) | 19.08 (0.751) | 17.41 (0.685) | 35.20 (1.386) | 24.04 (0.947) | 21.00 (0.826) | 22.50 (0.886) |
| 14 | 34.92 (1.374) | 30.18 (1.188) | 38.51 (1.516) | 22.22 (0.875) | 20.57 (0.810) | 38.40 (1.512) | 26.87 (1.058) | 24.08 (0.948) | 25.70 (1.012) |
| 16 | 38.10 (1.500) | 33.32 (1.312) | 41.02 (1.615) | 25.43 (1.001) | 23.74 (0.935) | 41.00 (1.614) | 31.11 (1.225) | 27.23 (1.072) | 28.83 (1.135) |
| 18 | 41.27 (1.624) | 36.53 (1.438) | 44.86 (1.766) | 28.60 (1.126) | 26.91 (1.059) | 44.70 (1.760) | 35.35 (1.392) | 30.41 (1.197) | 32.01 (1.260) |
| 20 | 46.02 (1.812) | 39.67 (1.562) | 49.61 (1.953) | 31.77 (1.251) | 30.08 (1.184) | 47.85 (1.884) | 38.18 (1.503) | 33.58 (1.322) | 35.18 (1.385) |
| 22 | 49.23 (1.938) | 42.88 (1.688) | 52.78 (2.078) | 34.95 (1.376) | 33.26 (1.309) | 51.00 (2.008) | 41.01 (1.615) | 36.95 (1.455) | 38.36 (1.510) |
| 24 | 52.37 (2.062) | 46.02 (1.812) | 55.96 (2.203) | 38.13 (1.501) | 36.43 (1.434) | 55.75 (2.195) | 43.84 (1.726) | 39.93 (1.572) | 41.53 (1.635) |

See page 29 for insert arrangements and back cover for configuration sheet.



DEUTSCH AS Series Filter Connectors

2-Hole Flange Receptacles

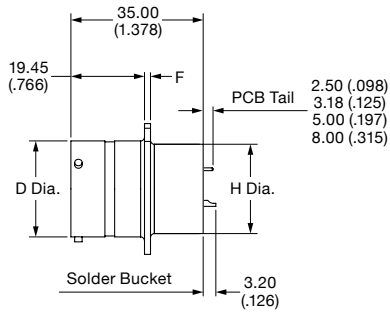

Single Flange

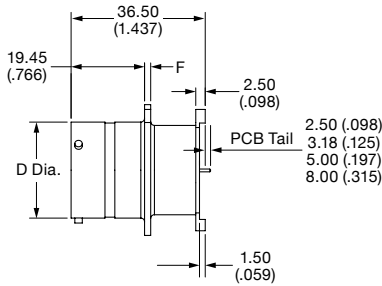

Double Flange

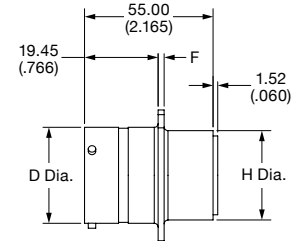

Single Flange, Crimp Contacts

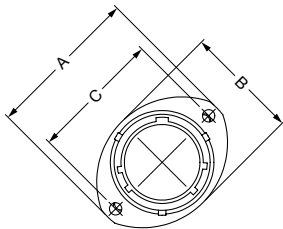

Front View

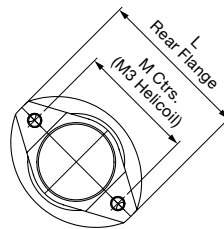

Double Flange Footprint

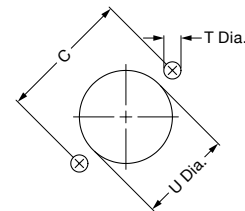

Flange Mounting

| A Max. | B | C Ref. | D Dia. Max. | F | H Dia. Max. | L Max. | M | Mounting Holes | |
|------------------|------------------|------------------|------------------|-----------------|------------------|------------------|------------------|------------------|------------------|
| | | | | | | | | T Dia. | U Dia. Max. |
| 27.50 (1.083) | 16.50 (0.650) | 21.40 (0.843) | 12.04 (0.474) | | 11.10 (0.437) | 27.50 (1.083) | 19.80 (0.779) | | 14.50 (0.571) |
| 32.00 (1.260) | 19.50 (0.768) | 25.90 (1.020) | 15.01 (0.591) | | 14.30 (0.563) | 32.00 (1.260) | 19.80 (0.779) | | 17.40 (0.685) |
| 35.20 (1.386) | 24.00 (0.945) | 29.10 (1.146) | 19.08 (0.751) | | 17.45 (0.687) | 35.20 (1.386) | 24.04 (0.947) | | 21.90 (0.862) |
| 38.40 (1.512) | 27.00 (1.063) | 32.50 (1.280) | 22.25 (0.876) | 1.62 (0.064) | 20.60 (0.811) | 38.40 (1.512) | 26.87 (1.058) | 3.6 (0.142) | 25.00 (0.984) |
| 41.00 (1.614) | 30.30 (1.193) | 34.80 (1.370) | 25.43 (1.001) | | 23.80 (0.937) | 41.00 (1.614) | 31.11 (1.225) | | 28.20 (1.110) |
| 44.70 (1.760) | 33.70 (1.327) | 38.20 (1.504) | 28.60 (1.126) | | 26.95 (1.061) | 44.70 (1.760) | 35.35 (1.392) | | 31.40 (1.236) |
| 47.90 (1.886) | 37.00 (1.457) | 41.60 (1.638) | 31.77 (1.251) | | 30.10 (1.185) | 47.85 (1.884) | 38.18 (1.503) | | 34.60 (1.362) |
| 51.10 (2.011) | 40.00 (1.575) | 44.90 (1.768) | 34.95 (1.376) | 2.38 (0.094) | 33.26 (1.309) | 51.00 (2.008) | 41.01 (1.615) | | 37.80 (1.488) |
| 55.80 (2.197) | 43.30 (1.705) | 49.30 (1.941) | 38.13 (1.501) | | 36.43 (1.434) | 55.75 (2.195) | 43.84 (1.726) | 41.00 (1.614) | 41.00 (1.614) |

See page 29 for insert arrangements and back cover for configuration sheet.



DEUTSCH AS Series Filter Connectors

Plug

| Shell Size | A Dia. Max. |
|------------|------------------|
| 8 | 17.70 (0.697) |
| 10 | 20.80 (0.819) |
| 12 | 25.20 (0.992) |
| 14 | 28.40 (1.118) |
| 16 | 31.50 (1.240) |
| 18 | 34.80 (1.370) |
| 20 | 38.10 (1.500) |
| 22 | 41.20 (1.622) |
| 24 | 44.50 (1.752) |

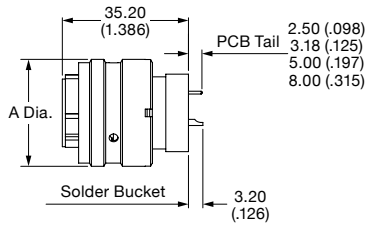

PCB/Solder Bucket Contacts

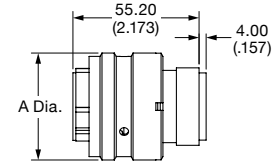

Crimp Contacts

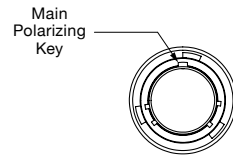

Front View

Keying Options

(Viewed from Mating Face of the Receptacle Connector)

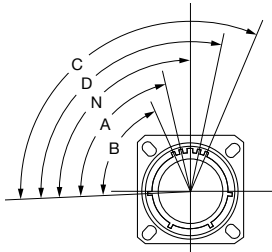

| Shell Size | Key Position | | | | |
|------------|--------------|----|----|-----|-----|
| | N | A | B | C | D |
| 9 | 95 | 77 | — | — | 113 |
| 11 | 95 | 81 | 67 | 123 | 109 |
| 13 | 95 | 75 | 63 | 127 | 115 |
| 15 | 95 | 74 | 61 | 129 | 116 |
| 17 | 95 | 77 | 65 | 125 | 113 |
| 19 | 95 | 77 | 65 | 125 | 113 |
| 21 | 95 | 77 | 65 | 125 | 113 |
| 23 | 95 | 80 | 69 | 121 | 110 |
| 25 | 95 | 80 | 69 | 121 | 110 |

See page 29 for insert arrangements and back cover for configuration sheet.



Insert Arrangements

- **Filter Connector Series:** H91, H92, H93, H94, HDJ, AS
- **Industry Specification:** MIL-DTL-38999
- **Insert Arrangement Specification:** MIL-STD-1560
- **Notes:** H91, H92, H93, H94 connectors use odd numbers for shell sizes
 HDJ and AS connectors use even numbers for shell sizes
 Shaded rows are TE-specific configurations not covered in MIL-STD-1560

| Shell Size | Arrangement | Contact Size and Type | | | | | | | | | | | | | |
|---------------|-----------------------|-----------------------|---|--------|--------|---------|---------|---------|----|----|----|----|----|----|----|
| | | 0 | 4 | 8 Twin | 8 Coax | 8 Power | 12 Twin | 12 Coax | 10 | 12 | 16 | 20 | 22 | 23 | 24 |
| 9 (8) | 09-98 (08-98) | – | – | – | – | – | – | – | – | – | – | 3 | – | – | – |
| | 09-35 (08-35) | – | – | – | – | – | – | – | – | – | – | – | 6 | – | – |
| | 09-07 (08-07) | – | – | – | – | – | – | – | – | – | – | – | – | 7 | – |
| | 09-23 (08-23) | – | – | – | – | – | – | – | – | – | – | – | – | – | 9 |
| | 09-11 (08-11) | – | – | – | – | – | – | – | – | – | – | – | – | – | 11 |
| 11 (10) | 11-02 (10-02) | – | – | – | – | – | – | – | – | – | 2 | – | – | – | – |
| | 11-04 (10-04) | – | – | – | – | – | – | – | – | – | – | 4 | – | – | – |
| | 11-05 (10-05) | – | – | – | – | – | – | – | – | – | – | – | 5 | – | – |
| | 11-98 (10-98) | – | – | – | – | – | – | – | – | – | – | – | 6 | – | – |
| | 11-99 (10-99) | – | – | – | – | – | – | – | – | – | – | – | 7 | – | – |
| | 11-35 (10-35) | – | – | – | – | – | – | – | – | – | – | – | – | 13 | – |
| | 11-23 (10-23) | – | – | – | – | – | – | – | – | – | – | – | – | – | 19 |
| 11-23 (10-23) | – | – | – | – | – | – | – | – | – | – | – | – | – | – | 23 |
| 13 (12) | 13-04 (12-04) | – | – | – | – | – | – | – | – | – | 4 | – | – | – | – |
| | 13-08 (12-08) | – | – | – | – | – | – | – | – | – | – | 8 | – | – | – |
| | 13-98 (12-98) | – | – | – | – | – | – | – | – | – | – | 10 | – | – | – |
| | 13-35 (12-35) | – | – | – | – | – | – | – | – | – | – | – | 22 | – | – |
| | 13-23 (12-23) | – | – | – | – | – | – | – | – | – | – | – | – | 32 | – |
| | 13-41 (12-41) | – | – | – | – | – | – | – | – | – | – | – | – | – | 41 |
| 15 (14) | 15-05 (14-08) | – | – | – | – | – | – | – | – | – | 5 | – | – | – | – |
| | 15-97 (14-97) | – | – | – | – | – | – | – | – | – | 4 | 8 | – | – | – |
| | 15-15 (14-15) | – | – | – | – | – | – | – | – | – | 1 | 14 | – | – | – |
| | 15-18 (14-18) | – | – | – | – | – | – | – | – | – | – | 18 | – | – | – |
| | 15-19 (14-18) | – | – | – | – | – | – | – | – | – | – | 19 | – | – | – |
| | 15-26 (14-26) | – | – | – | – | – | – | – | – | – | 2 | – | 24 | – | – |
| | 15-35 (14-35) | – | – | – | – | – | – | – | – | – | – | – | 37 | – | – |
| | 15-23 (14-23) | – | – | – | – | – | – | – | – | – | – | – | – | – | 55 |
| | 15-64 (14-64) | – | – | – | – | – | – | – | – | – | – | – | – | – | 64 |
| 17 (16) | 17-22 (16-22) | – | – | 2 | – | – | – | – | – | 2 | – | – | – | – | – |
| | 17-06 (16-06) | – | – | – | – | – | – | – | – | 6 | – | – | – | – | – |
| | 17-08 (16-08) | – | – | – | – | – | – | – | – | – | 8 | – | – | – | – |
| | 17-11 (16-11) | – | – | 2 | 1 | – | – | – | – | – | 8 | – | – | – | – |
| | 17-19 (16-19) | – | – | – | – | – | – | – | – | – | 4 | 11 | 4 | – | – |
| | 17-20 (16-20) | – | – | – | – | – | – | – | – | 4 | – | – | 16 | – | – |
| | 17-99 (16-99) | – | – | – | – | – | – | – | – | – | 2 | 21 | – | – | – |
| | 17-24 (16-24) | – | – | – | – | 2 | – | – | – | – | – | – | 22 | – | – |
| | 17-26 (16-26) | – | – | – | – | – | – | – | – | – | – | 26 | – | – | – |
| | 17-03 [17-02] (16-03) | – | – | – | – | – | – | – | – | – | – | – | – | 38 | – |
| | 17-35 (16-35) | – | – | – | – | – | – | – | – | – | – | – | – | 55 | – |
| | 17-23 (16-23) | – | – | – | – | – | – | – | – | – | – | – | – | – | 73 |



Insert Arrangements

| Shell Size | Arrangement | Contact Size and Type | | | | | | | | | | | | | |
|--------------------------|--------------------------|-----------------------|---|--------|--------|---------|---------|---------|----|----|-----|----|-----|----|-----|
| | | 0 | 4 | 8 Twin | 8 Coax | 8 Power | 12 Twin | 12 Coax | 10 | 12 | 16 | 20 | 22 | 23 | 24 |
| 19 (18) | 19-11 (18-11) | — | — | — | — | — | — | — | — | — | 11 | — | — | — | — |
| | 19-19 [19-18] 18-18 | — | — | 4 | — | — | — | — | — | — | — | — | 14 | — | — |
| | 19-28 (18-28) | — | — | — | — | — | — | — | — | — | 2 | 26 | — | — | — |
| | 19-32 (18-32) | — | — | — | — | — | — | — | — | — | — | 32 | — | — | — |
| | 19-35 (18-35) | — | — | — | — | — | — | — | — | — | — | — | 66 | — | — |
| | 19-23 (18-23) | — | — | — | — | — | — | — | — | — | — | — | — | 88 | — |
| | 19-118 (18-118) | — | — | — | — | — | — | — | — | — | — | — | — | — | 118 |
| 21 (20) | 21-76 [21-75] (20-76) | — | — | 4 | — | — | — | — | — | — | — | — | — | — | — |
| | 21-48 (20-48) | — | — | — | — | 4 | — | — | — | — | — | — | — | — | — |
| | 21-11 (20-11) | — | — | — | — | — | — | — | 11 | — | — | — | — | — | — |
| | 21-16 (20-16) | — | — | — | — | — | — | — | — | 16 | — | — | — | — | — |
| | 21-20 (20-20) | — | — | 2 | — | — | — | — | — | — | 18 | — | — | — | — |
| | 21-39 (20-39) | — | — | — | — | — | — | — | — | — | 2 | 37 | — | — | — |
| | 21-41 (20-41) | — | — | — | — | — | — | — | — | — | — | 41 | — | — | — |
| | 21-35 (20-35) | — | — | — | — | — | — | — | — | — | — | — | 79 | — | — |
| 21-23 (20-23) | — | — | — | — | — | — | — | — | — | — | — | — | 121 | — | |
| 23 (22) | 23-100 (22-100) | 1 | — | — | — | — | — | — | — | — | — | — | — | — | — |
| | 23-24320 (22-24320) | — | 2 | — | — | — | — | — | — | — | — | 3 | — | — | — |
| | 23-68 (22-68) | — | — | — | — | 6 | — | — | — | — | — | — | — | — | — |
| | 23-06 (22-06) | — | — | 6 | — | — | — | — | — | — | — | — | — | — | — |
| | 23-21 (22-21) | — | — | — | — | — | — | — | — | 21 | — | — | — | — | — |
| | 23-54 (22-54) | — | — | — | — | — | — | — | 4 | 9 | — | 40 | — | — | — |
| | 23-53 (22-53) | — | — | — | — | — | — | — | — | — | 53 | — | — | — | — |
| | 23-55 (22-55) | — | — | — | — | — | — | — | — | — | 55 | — | — | — | — |
| | 23-63 (22-63) | — | — | — | — | — | — | — | 4 | 4 | — | 49 | — | — | — |
| 23-35 (22-35) | — | — | — | — | — | — | — | — | — | — | 100 | — | — | — | |
| 23-23 (22-23) | — | — | — | — | — | — | — | — | — | — | — | — | 151 | — | |
| 25 (24) | 25-44420 (24-44420) | — | 4 | — | — | — | — | — | — | — | 4 | — | — | — | — |
| | 25-08 (24-08) | — | 8 | — | — | — | — | — | — | — | — | — | — | — | — |
| | 25-11 (24-11) | — | — | — | — | — | — | — | 9 | — | 2 | — | — | — | — |
| | 25-24 (24-24) | — | — | — | — | — | — | — | — | 12 | 12 | — | — | — | — |
| | 25-21 [25-20] (24-21) | — | — | 3 | — | — | — | 4 | — | — | 13 | 10 | — | — | — |
| | 25-19 (24-19) | — | — | — | — | — | — | — | — | 19 | — | — | — | — | — |
| | 25-29 (24-29) | — | — | — | — | — | — | — | — | — | 29 | — | — | — | — |
| | 25-37 (24-37) | — | — | — | — | — | — | — | — | — | 37 | — | — | — | — |
| | 25-17 (24-17) | — | — | 6 | — | — | — | — | — | — | — | 36 | — | — | — |
| | 25-43 (24-43) | — | — | — | — | — | — | — | — | — | 20 | 23 | — | — | — |
| | 25-47 [25-46] (24-47) | — | — | — | 2 | — | — | — | — | — | 4 | 40 | — | — | — |
| | 25-91 [25-90] (24-91) | — | — | 2 | — | — | — | — | — | — | 4 | 40 | — | — | — |
| | 25-04 (24-04) | — | — | — | — | — | — | — | — | — | 8 | 48 | — | — | — |
| | 25-35 (24-35) | — | — | — | — | — | — | — | — | — | — | — | 128 | — | — |
| | 25-61 (24-61) | — | — | — | — | — | — | — | — | — | — | 61 | — | — | — |
| 25-09 [25-07] (24-09) | — | — | 2 | — | — | — | — | — | — | — | — | 97 | — | — | |
| 25-23 (24-23) | — | — | — | — | — | — | — | — | — | — | — | — | 187 | — | |



DEUTSCH RR Series Filter Connectors

MIL-DTL-26482 SERIES 2



DEUTSCH RR Series connectors are medium-density, MIL-DTL-26482 Series 2 circular connectors using a bayonet coupling with visible mating indication. The bayonet coupling requires 1/3 turn to mate fully. Available with crimp contacts, PC tails, solder cups and headers, they feature various plating options available and numerous keying options.

SPECIFICATIONS

Environmental

- **Temperature Range:** -55°C to 125°C
- **Physical Shock:** Typical to EIA-364-27
- **Vibration:** Typical to EIA-364-28 test condition III
- **Fungus Resistance:** Based on MIL-STD-810
- **Fluid Immersion:** Typical as per MIL-DTL-26482 classes H, L and N (Table XXIX)
- **Salt Spray:** Typically based on EIA/ECA-364-26
- **Humidity:** Typically EIA-364-31 test method II
- **Durability:** 500 cycles per MIL-DTL-26482

Electrical

- **Grounded Line Resistance (Typ.):** 15 mΩ
- **Insulation Resistance (Typ.):** >5 GΩ
- **Dielectric Withstand (Typ.):** <5 μA
- **DWV:** up to 2000 VDC
- **Working Voltage:** up to 2000 VDC
- **Typical Test Specifications Used:**
 Mil-STD-810: Test Method Standard
 Mil-STD-202: Electrical & Electronic Component Parts
 RTCA DO-160: Test Procedures for Airborne Equipment
 EIA-364: Electrical Connector & Socket Test Procedures

Filtering

- **Capacitance Range:** 20 pF to 4 μF
- **Capacitance Tolerance:** Typically 20%
- **Unfiltered Line Cap (Typ.):** 15 pF
- **Filtering Topologies:** L, C, LC, CL, Pi, T, Double T

Transient protection available as per RTCA Publication DO 160 (see page 55).

MATING COMPATIBILITY

- MIL-DTL-26482 Series 2 connectors
- DEUTSCH RR/602 connectors

RELIABLE

- Three-point bayonet coupling
- 100% scoop proof
- RFI shell-to-shell continuity

VERSATILE

- Wide range of connector shell configurations
- Configurable filter topologies

DESIGNED FOR HARSH ENVIRONMENTS

- Vibration and shock
- Temperature extremes
- High humidity
- Altitude
- Salt spray



DEUTSCH RR Series Filter Connectors

MIL-DTL-26482 SERIES II

Jam Nut Receptacles

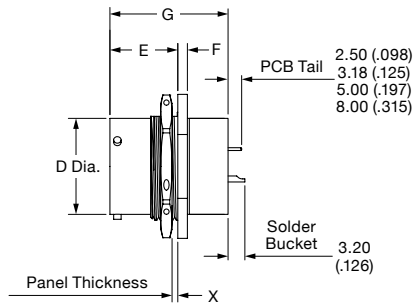

Single Flange

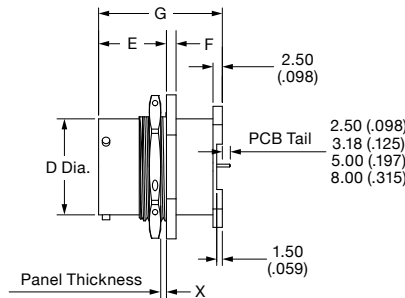

Double Flange

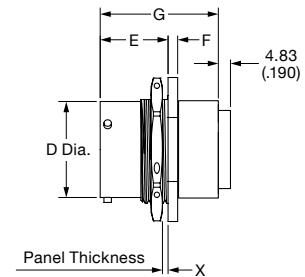

Single Flange, Crimp Contacts

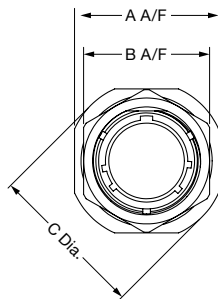

Front View

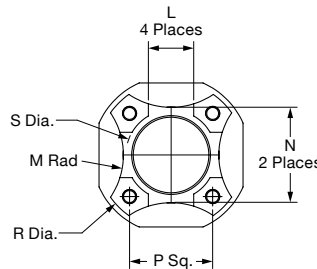

Double Flange Footprint

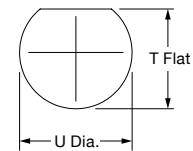

Recommended Panel Cutout

| Shell Size | A A/F | B A/F | C Dia. Max. | D Dia. Max. | E Max. | F Max. | G Max. | | | X Panel Thickness | L Ref. | M Rad Ref. | N Ref. | P Sq. | R Dia. | S Dia. | Mounting Dims | |
|------------|------------------|------------------|------------------|------------------|------------------|-----------------|------------------|------------------|------------------|-------------------------------|------------------|------------------|------------------|------------------|------------------|------------------|------------------|------------------|
| | | | | | | | Single Flange | Double Flange | Crimp | | | | | | | | T Flat | U Dia. |
| 8 | 23.83 (0.938) | 19.05 (0.750) | 27.38 (1.078) | 12.04 (0.474) | | | | | | 1.57 to 4.75 (0.062-0.187) | 8.00 (0.315) | 9.00 (0.354) | 15.50 (0.610) | 14.00 (0.551) | 27.06 (1.065) | 14.34 (0.565) | 13.62 (0.536) | 14.53 (0.572) |
| 10 | 26.97 (1.061) | 22.22 (0.875) | 30.56 (1.203) | 15.01 (0.591) | | | | | | 1.57 to 4.75 (0.062-0.187) | 8.00 (0.315) | 12.00 (0.472) | 17.15 (0.675) | 14.00 (0.551) | 30.06 (1.183) | 14.34 (0.565) | 16.79 (0.661) | 17.70 (0.697) |
| 12 | 31.75 (1.250) | 26.97 (1.062) | 35.33 (1.391) | 19.08 (0.751) | 17.95 (0.707) | 2.87 (0.113) | 30.86 (1.215) | 32.36 (1.274) | 50.86 (2.002) | 1.57 to 4.75 (0.062-0.187) | 8.00 (0.315) | 18.00 (0.709) | 19.90 (0.783) | 17.00 (0.669) | 35.06 (1.380) | 17.42 (0.686) | 21.00 (0.826) | 22.50 (0.886) |
| 14 | 34.92 (1.374) | 30.18 (1.188) | 38.51 (1.516) | 22.25 (0.876) | | | | | | 1.57 to 4.75 (0.062-0.187) | 12.00 (0.472) | 22.00 (0.866) | 23.10 (0.909) | 19.00 (0.748) | 36.06 (1.420) | 20.72 (0.816) | 24.08 (0.948) | 25.70 (1.012) |
| 16 | 38.10 (1.500) | 33.32 (1.312) | 41.68 (1.641) | 25.43 (1.001) | | | | | | 1.57 to 4.75 (0.062-0.187) | 12.00 (0.472) | 24.00 (0.945) | 26.25 (1.033) | 22.00 (0.866) | 40.06 (1.577) | 23.89 (0.941) | 27.23 (1.072) | 28.83 (1.135) |
| 18 | 41.27 (1.624) | 36.53 (1.438) | 44.86 (1.766) | 28.60 (1.126) | | | | | | 1.57 to 4.75 (0.062-0.187) | 16.00 (0.630) | 24.00 (0.945) | 29.45 (1.159) | 25.00 (0.984) | 40.06 (1.577) | 26.43 (1.041) | 30.41 (1.197) | 32.01 (1.260) |
| 20 | 46.02 (1.812) | 39.67 (1.562) | 49.61 (1.953) | 31.77 (1.251) | | | | | | 1.57 to 6.35 (0.062-0.250) | 16.00 (0.630) | 25.00 (0.984) | 31.90 (1.256) | 27.00 (1.063) | 44.06 (1.735) | 29.58 (1.165) | 33.58 (1.322) | 35.18 (1.385) |
| 22 | 49.23 (1.938) | 42.88 (1.688) | 52.78 (2.078) | 34.95 (1.376) | 19.61 (0.772) | 3.76 (0.148) | 32.38 (1.275) | 33.88 (1.334) | 52.38 (2.062) | 1.57 to 6.35 (0.062-0.250) | 16.00 (0.630) | 27.00 (1.063) | 38.10 (1.500) | 31.00 (1.221) | 51.06 (2.010) | 35.83 (1.411) | 36.95 (1.455) | 38.36 (1.510) |
| 24 | 52.37 (2.062) | 46.02 (1.812) | 55.96 (2.203) | 38.13 (1.501) | | | | | | 1.57 to 5.56 (0.062-0.219) | 16.00 (0.630) | 27.00 (1.063) | 38.10 (1.500) | 31.00 (1.221) | 51.06 (2.010) | 35.83 (1.411) | 39.93 (1.572) | 41.53 (1.635) |

See page 35 for insert arrangements and back cover for configuration sheet.



DEUTSCH RR Series Filter Connectors

MIL-DTL-26482 SERIES II

Square Flange Receptacles

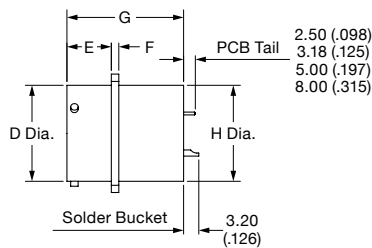

Single Flange

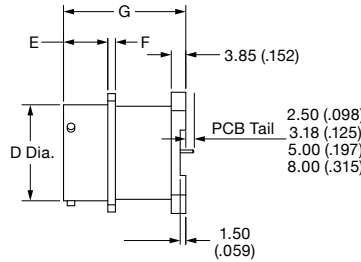

Double Flange

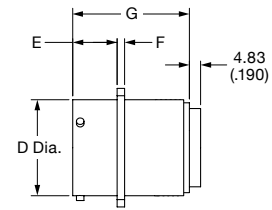

Single Flange, Crimp Contacts

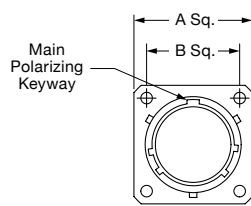

Front View

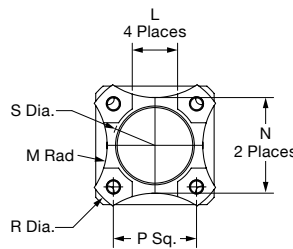

Double Flange Footprint

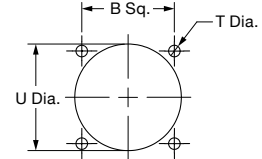

Square Flange Mounting

| Shell Size | A Sq. Max. | B Sq. | D Dia. Max. | E Max. | F Max. | Length G Max. | | | H Dia. Max. | L Ref. | M Rad Ref. | N Ref. | P Sq. | R Dia. | S Dia. | Mounting Holes | |
|------------|------------------|------------------|------------------|------------------|-----------------|------------------|------------------|------------------|------------------|------------------|------------------|------------------|------------------|------------------|------------------|-----------------|------------------|
| | | | | | | Single Flange | Double Flange | Crimp | | | | | | | | T Dia. | U Dia. Max. |
| 8 | 21.03 (0.828) | 15.09 (0.594) | 12.04 (0.474) | | | | | | 15.09 (0.594) | 8.00 (0.315) | 9.00 (0.354) | 15.50 (0.610) | 14.00 (0.551) | 27.06 (1.065) | 14.34 (0.565) | | 14.55 (0.573) |
| 10 | 24.23 (0.954) | 18.26 (0.719) | 15.01 (0.591) | | | | | | 15.09 (0.594) | 8.00 (0.315) | 12.00 (0.472) | 17.15 (0.675) | 14.00 (0.551) | 30.06 (1.183) | 14.34 (0.565) | | 17.53 (0.690) |
| 12 | 26.59 (1.047) | 20.62 (0.812) | 19.08 (0.751) | 11.73 (0.462) | 1.98 (0.078) | 30.86 (1.215) | 32.36 (1.274) | 50.86 (2.002) | 18.26 (0.719) | 8.00 (0.315) | 18.00 (0.709) | 19.90 (0.783) | 17.00 (0.669) | 35.06 (1.380) | 17.42 (0.686) | | 22.07 (0.869) |
| 14 | 28.98 (1.141) | 23.01 (0.906) | 22.25 (0.876) | | | | | | 21.44 (0.844) | 12.00 (0.472) | 22.00 (0.866) | 23.10 (0.909) | 19.00 (0.748) | 36.06 (1.420) | 20.72 (0.816) | 3.05 (0.120) | 25.25 (0.994) |
| 16 | 31.34 (1.234) | 24.61 (0.969) | 25.43 (1.001) | | | | | | 24.61 (0.969) | 12.00 (0.472) | 24.00 (0.945) | 26.25 (1.033) | 22.00 (0.866) | 40.06 (1.577) | 23.89 (0.941) | | 28.40 (1.118) |
| 18 | 33.73 (1.328) | 26.97 (1.062) | 28.60 (1.126) | | | | | | 27.38 (1.078) | 16.00 (0.630) | 24.00 (0.945) | 29.45 (1.159) | 25.00 (0.984) | 40.06 (1.577) | 26.43 (1.041) | | 31.57 (1.243) |
| 20 | 36.91 (1.453) | 29.36 (1.156) | 31.77 (1.251) | 14.91 (0.587) | | | | | 30.56 (1.203) | 16.00 (0.630) | 25.00 (0.984) | 31.90 (1.256) | 27.00 (1.063) | 44.06 (1.735) | 29.58 (1.165) | | 34.75 (1.368) |
| 22 | 40.08 (1.578) | 31.75 (1.250) | 34.95 (1.376) | | 2.79 (0.110) | 32.39 (1.275) | 33.89 (1.334) | 52.38 (2.062) | 33.73 (1.328) | 16.00 (0.630) | 27.00 (1.063) | 35.05 (1.379) | 29.00 (1.142) | 46.06 (1.813) | 32.76 (1.290) | | 37.92 (1.493) |
| 24 | 43.26 (1.703) | 34.93 (1.375) | 38.13 (1.501) | 15.75 (0.620) | | | | | 36.91 (1.453) | 16.00 (0.630) | 27.00 (1.063) | 38.10 (1.500) | 31.00 (1.221) | 51.06 (2.010) | 35.83 (1.411) | 3.74 (0.147) | 41.15 (1.620) |

See page 35 for insert arrangements and back cover for configuration sheet.



DEUTSCH RR Series Filter Connectors

MIL-DTL-26482 SERIES 2

Plugs

| Shell Size | A Dia. | W Thread Class 2A |
|------------|------------------|-------------------|
| 8 | 22.41 (0.882) | 0.5000-20 UNF |
| 10 | 25.59 (1.007) | 0.6250-24 UNEF |
| 12 | 28.78 (1.132) | 0.7500-20 UNEF |
| 14 | 31.94 (1.257) | 0.8750-20 UNEF |
| 16 | 36.69 (1.447) | 1.0000-20 UNEF |
| 18 | 39.46 (1.553) | 1.0625-18 UNEF |
| 20 | 42.41 (1.677) | 1.1875-18 UNEF |
| 22 | 45.40 (1.787) | 1.3125-18 UNEF |
| 24 | 48.57 (1.912) | 1.4375-18 UNEF |

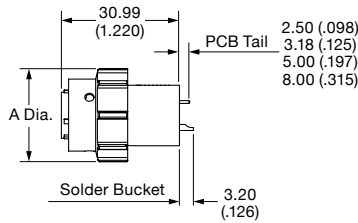

PCB/Solder Bucket Contacts

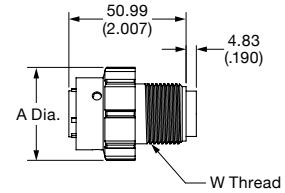

Crimp Contacts

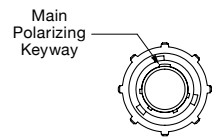

Front View

Keying Options

(Plug Mating Face Shown)

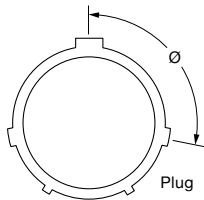

| Shell Size | Key Position (Degrees) | | | | |
|------------|------------------------|----|-----|-----|-----|
| | N | B | C | E | G |
| 8 | 105 | — | — | 118 | 82 |
| 10 | 105 | 85 | 125 | 115 | 85 |
| 12 | 105 | 89 | 121 | 115 | 85 |
| 14 | 105 | 91 | 119 | 75 | 120 |
| 16 | 105 | 93 | 117 | 75 | 120 |
| 18 | 105 | 95 | 115 | 75 | 120 |
| 20 | 105 | 95 | 115 | 75 | 120 |
| 22 | 105 | 97 | 113 | 75 | 120 |
| 24 | 105 | 97 | 113 | 75 | 120 |

See page 35 for insert arrangements and back cover for configuration sheet.



DEUTSCH RR Series Filter Connectors MIL-DTL-26482 SERIES 2

Insert Arrangements

- Filter Connector Series: RR
- Industry Specification: MIL-DTL-26482 Series II
- Insert Arrangement Specification: MIL-STD-1651

| Shell Size | Arrangement | Contact Size and Type | | | | |
|------------|-------------|-----------------------|----|----|----|------|
| | | 20 | 16 | 14 | 12 | Coax |
| 8 | 8-33 | 3 | — | — | — | — |
| | 8-98 | 3 | — | — | — | — |
| 10 | 10-6 | 6 | — | — | — | — |
| | 10-98 | 6 | — | — | — | — |
| 12 | 12-3 | — | 3 | — | — | — |
| | 12-10 | 10 | — | — | — | — |
| | 12-8 | 8 | — | — | — | — |
| 14 | 14-4 | — | — | — | 4 | — |
| | 14-5 | — | 5 | — | — | — |
| | 14-12 | 8 | 4 | — | — | — |
| | 14-15 | 14 | 1 | — | — | — |
| | 14-18 | 18 | — | — | — | — |
| | 14-19 | 19 | — | — | — | — |
| 16 | 16-8 | — | 8 | — | — | — |
| | 16-23 | 22 | 1 | — | — | — |
| | 16-26 | 26 | — | — | — | — |
| 18 | 16-99 | 21 | 2 | — | — | — |
| | 18-8 | — | — | — | 8 | — |
| | 18-11 | — | 11 | — | — | — |
| | 18-30 | 29 | 1 | — | — | — |
| 20 | 18-32 | 32 | — | — | — | — |
| | 20-16 | — | 16 | — | — | — |
| | 20-39 | 37 | 2 | — | — | — |
| 22 | 20-41 | 41 | — | — | — | — |
| | 22-7 | — | — | — | — | 7 |
| | 22-12 | — | — | — | 12 | — |
| | 22-21 | — | 21 | — | — | — |
| | 22-36 | 36 | — | — | — | — |
| | 22-41 | 27 | 14 | — | — | — |
| 24 | 22-55 | 55 | — | — | — | — |
| | 24-19 | — | — | — | 19 | — |
| | 24-31 | — | 31 | — | — | — |
| | 24-61 | 61 | — | — | — | — |
| | 24-100 | — | — | — | — | 10 |



DEUTSCH FDBA Series Filter Connectors

NAS1599B



MATING COMPATIBILITY

- DEUTSCH RR/602 connectors
- ASNE connectors

VERSATILE

- Wide range of connector

SHELL CONFIGURATIONS

- Configurable filter topologies

RELIABLE

- Positive bayonet coupling
- High durability silicone elastomers

DESIGNED FOR HARSH ENVIRONMENTS

- Vibration and shock
- Temperature extremes
- High humidity
- Altitude
- Salt spray

DEUTSCH FDBA Series connectors were developed from the NAS1599B specification. The lightweight connectors offer medium-density insert arrangements, various plating options, five different keying options, and a bayonet coupling requiring only a 1/3 turn to mate fully.

SPECIFICATIONS

Environmental

- **Temperature Range:** -55°C to 125°C
- **Physical Shock:** Typical to EIA-364-27
- **Vibration:** Typical to EIA-364-28 test condition III
- **Fungus Resistance:** Based on MIL-STD-810
- **Fluid Immersion:** Typical as per MIL-DTL-26482 classes H, L and N (Table XXIX)
- **Salt Spray:** Typically based on EIA/ECA-364-26
- **Humidity:** Typically EIA-364-31 test method II
- **Durability:** 500 cycles per MIL-DTL-26482

Electrical

- **Grounded Line Resistance (Typ.):** 15 mΩ
- **Insulation Resistance (Typ.):** >5 GΩ
- **Dielectric Withstand (Typ.):** <5 μA
- **DWV:** up to 2000 VDC
- **Working Voltage:** up to 2000 VDC
- **Typical Test Specifications Used:**
MIL-STD-810: Test Method Standard
MIL-STD-202: Electrical & Electronic Component Parts
RTCA DO-160: Test Procedures for Airborne Equipment
EIA-364: Electrical Connector & Socket Test Procedures

Filtering

- **Capacitance Range:** 20 pF to 4 μF
- **Capacitance Tolerance:** Typically 20%
- **Unfiltered Line Cap (Typ.):** 15 pF
- **Filtering Topologies:** L, C, LC, CL, Pi, T, Double T

Transient protection available as per RTCA Publication DO 160 (see page 55).



DEUTSCH FDBA Series Filter Connectors

Jam Nut Receptacles

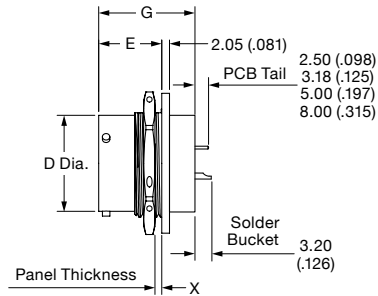

Single Flange

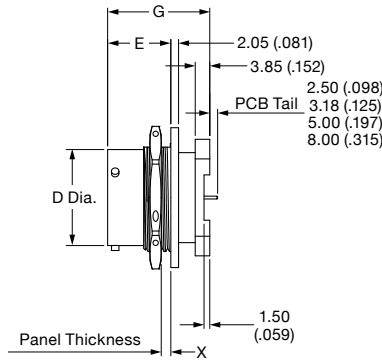

Double Flange

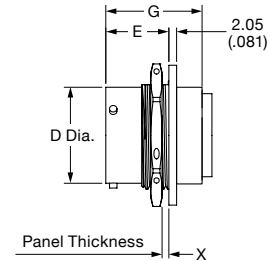

Single Flange, Crimp Contacts

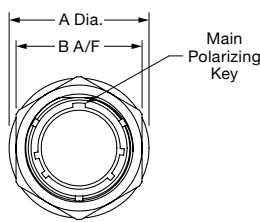

Front View

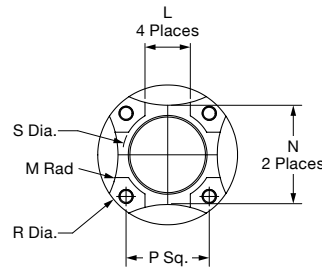

Double Flange Footprint

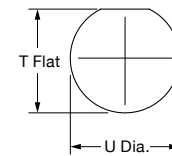

Recommended Panel Cutout

| Shell Size | A Dia. | B A/F Max. | D Dia. Max. | E Max. | Length G Max. | | | X Panel Thick. Max. | L Ref. | M Rad Ref. | N Ref. | P Sq. | R Dia. | S Dia. T Flat | Mounting Dims | |
|------------|------------------|------------------|------------------|------------------|------------------|------------------|------------------|---------------------|------------------|------------------|------------------|------------------|------------------|------------------|------------------|------------------|
| | | | | | Single Flange | Double Flange | Crimp | | | | | | | | | |
| 8 | 23.83 (0.938) | 12.04 (0.474) | 12.04 (0.474) | | | | | | 8.00 (0.315) | 9.00 (0.354) | 15.50 (0.610) | 14.00 (0.551) | 27.06 (1.065) | 14.34 (0.565) | 13.85 (0.545) | 14.70 (0.579) |
| 10 | 26.97 (1.061) | 15.01 (0.591) | 15.01 (0.591) | | | | | | 8.00 (0.315) | 9.00 (0.354) | 15.50 (0.610) | 14.00 (0.551) | 27.06 (1.065) | 14.34 (0.565) | 17.05 (0.671) | 17.85 (0.703) |
| 12 | 31.75 (1.250) | 19.08 (0.751) | 19.08 (0.751) | 16.70 (0.657) | 28.59 (1.122) | 30.00 (1.181) | 48.50 (1.909) | 4.75 (0.187) | 8.00 (0.315) | 12.00 (0.472) | 18.65 (0.734) | 17.00 (0.669) | 32.06 (1.262) | 17.42 (0.686) | 21.15 (0.833) | 22.60 (0.890) |
| 14 | 34.92 (1.374) | 22.25 (0.876) | 22.25 (0.876) | | | | | | 12.00 (0.472) | 18.00 (0.709) | 22.00 (0.866) | 19.00 (0.748) | 35.06 (1.380) | 20.72 (0.816) | 24.30 (0.957) | 25.75 (1.014) |
| 16 | 38.10 (1.500) | 25.43 (1.001) | 25.43 (1.001) | | | | | | 12.00 (0.472) | 20.00 (0.787) | 25.25 (0.994) | 22.00 (0.866) | 39.06 (1.538) | 23.89 (0.941) | 27.45 (1.081) | 28.95 (1.138) |
| 18 | 41.27 (1.624) | 28.60 (1.126) | 28.60 (1.126) | | | | | | 16.00 (0.630) | 22.00 (0.866) | 28.40 (1.118) | 25.00 (0.984) | 42.06 (1.656) | 26.43 (1.041) | 30.65 (1.207) | 32.10 (1.264) |
| 20 | 46.02 (1.812) | 39.82 (1.568) | 31.77 (1.251) | | | | | | 16.00 (0.630) | 22.00 (0.866) | 31.55 (1.242) | 27.00 (1.063) | 45.06 (1.774) | 29.58 (1.165) | 33.80 (1.331) | 35.30 (1.390) |
| 22 | 49.23 (1.938) | 43.02 (1.694) | 34.95 (1.376) | 19.10 (0.752) | 31.00 (1.220) | 32.50 (1.280) | 51.00 (2.008) | 6.35 (0.250) | 16.00 (0.630) | 22.00 (0.866) | 34.50 (1.358) | 29.00 (1.142) | 48.06 (1.892) | 32.76 (1.290) | 37.00 (1.457) | 38.45 (1.514) |
| 24 | 52.37 (2.062) | 46.17 (1.818) | 38.13 (1.501) | | | | | | 5.60 (0.220) | 16.00 (0.630) | 24.00 (0.945) | 37.30 (1.469) | 31.00 (1.221) | 51.06 (2.010) | 35.83 (1.411) | 40.15 (1.581) |

See page 40 for insert arrangements and back cover for configuration sheet.



DEUTSCH FDBA Series Filter Connectors

Square Flange Receptacles

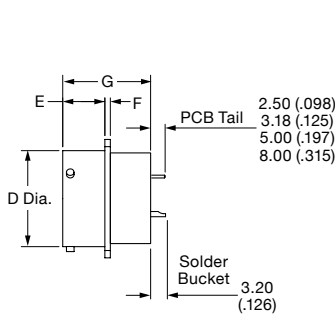

Single Flange

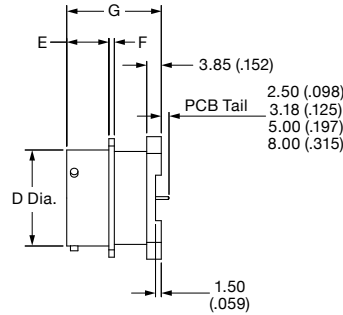

Double Flange

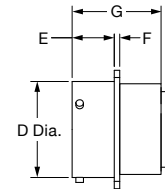

Single Flange, Crimp Contacts

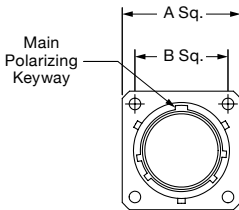

Front View

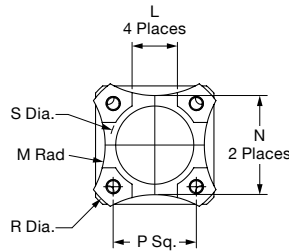

Double Flange Footprint

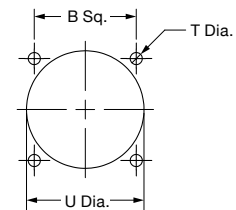

Square Flange Mounting

| Shell Size | A Sq. Max. | B Sq. | D Dia. Max. | E | F Max. | Length G | | | L Ref. | M Rad Ref. | N Ref. | P Sq. | R Dia. | S Dia. | Mounting Holes | |
|------------|------------------|------------------|------------------|------------------|-----------------|------------------|------------------|------------------|------------------|------------------|------------------|------------------|------------------|------------------|-----------------|------------------|
| | | | | | | Single Flange | Double Flange | Crimp | | | | | | | T Dia. | U Dia. |
| 8 | 21.03 (0.828) | 15.08 (0.594) | 12.03 (0.474) | | | | | | 8.00 (0.315) | 9.00 (0.354) | 15.50 (0.610) | 14.00 (0.551) | 27.06 (1.065) | 14.34 (0.565) | | 16.05 (0.632) |
| 10 | 24.23 (0.954) | 18.26 (0.719) | 15.01 (0.591) | | | | | | 8.00 (0.315) | 12.00 (0.472) | 18.65 (0.734) | 17.00 (0.669) | 32.06 (1.262) | 17.42 (0.686) | | 19.00 (0.748) |
| 12 | 26.59 (1.047) | 20.62 (0.812) | 19.07 (0.751) | | | | | | 12.00 (0.472) | 18.00 (0.709) | 22.00 (0.866) | 19.00 (0.748) | 35.06 (1.380) | 20.72 (0.816) | | 22.25 (0.876) |
| 14 | 28.98 (1.141) | 23.02 (0.906) | 22.24 (0.876) | 11.13 (0.438) | 1.45 (0.057) | 28.59 (1.122) | 30.00 (1.181) | 48.50 (1.909) | 12.00 (0.472) | 20.00 (0.787) | 25.25 (0.994) | 22.00 (0.866) | 39.06 (1.538) | 23.89 (0.941) | | 25.40 (1.000) |
| 16 | 31.34 (1.234) | 24.58 (0.968) | 25.42 (1.001) | | | | | | 16.00 (0.630) | 22.00 (0.866) | 28.40 (1.118) | 25.00 (0.984) | 42.06 (1.656) | 26.43 (1.041) | 3.15 (0.124) | 28.60 (1.126) |
| 18 | 33.73 (1.328) | 26.98 (1.062) | 28.60 (1.126) | | | | | | 16.00 (0.630) | 22.00 (0.866) | 31.55 (1.242) | 27.00 (1.063) | 45.06 (1.774) | 29.58 (1.165) | | 31.75 (1.250) |
| 20 | 36.91 (1.453) | 29.36 (1.156) | 31.77 (1.251) | | | | | | 16.00 (0.630) | 22.00 (0.866) | 34.50 (1.358) | 29.00 (1.142) | 48.06 (1.892) | 32.76 (1.290) | | 34.90 (1.374) |
| 22 | 40.08 (1.578) | 31.76 (1.250) | 34.94 (1.376) | 14.85 (0.585) | 2.25 (0.089) | 31.00 (1.220) | 32.50 (1.280) | 51.00 (2.008) | 16.00 (0.630) | 24.00 (0.945) | 37.30 (1.469) | 31.00 (1.221) | 51.06 (2.010) | 35.83 (1.411) | | 38.10 (1.500) |
| 24 | 43.26 (1.703) | 34.92 (1.375) | 38.12 (1.501) | 15.70 (0.618) | | | | | 16.00 (0.630) | 24.00 (0.945) | 37.30 (1.469) | 31.00 (1.221) | 51.06 (2.010) | 35.83 (1.411) | 3.73 (0.147) | 41.30 (1.626) |

See page 40 for insert arrangements and back cover for configuration sheet.



DEUTSCH FDBA Series Filter Connectors

Plugs

| Shell Size | A Dia. | B Max. | C Max. | W Thread Class 2A |
|------------|------------------|------------------|------------------|-------------------|
| 8 | 17.75 (0.699) | | | 0.5000-20 UNF |
| 10 | 21.05 (0.829) | | | 0.6250-24 UNEF |
| 12 | 24.60 (0.969) | 28.60 (1.126) | 48.60 (1.913) | 0.7500-20 UNEF |
| 14 | 28.05 (1.104) | | | 0.8750-20 UNEF |
| 16 | 31.10 (1.224) | | | 1.0000-20 UNEF |
| 18 | 34.40 (1.354) | | | 1.0625-18 UNEF |
| 20 | 37.65 (1.482) | | | 1.1875-18 UNEF |
| 22 | 40.90 (1.610) | 30.10 (1.185) | 50.10 (1.972) | 1.3125-18 UNEF |
| 24 | 44.10 (1.736) | | | 1.4375-18 UNEF |

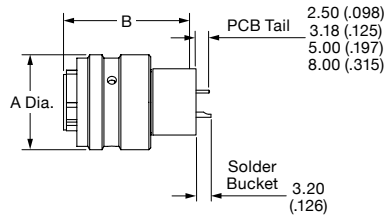

PCB/Solder Bucket Contacts

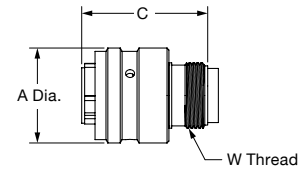

Crimp Contacts

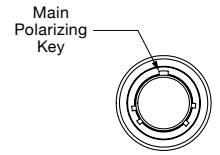

Front View

Keying Options (Plug Mating Face Shown)

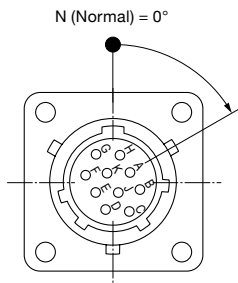

| Insert Arrangement | Position (Degrees) | | | |
|--------------------|--------------------|-----|-----|-----|
| | W | X | Y | Z |
| 8-3A/8-98 | 60 | — | — | — |
| 8-33 | 90 | — | — | — |
| 10-6 | 90 | — | — | — |
| 12-3 | — | — | 180 | — |
| 12-8 | 90 | 112 | 203 | 292 |
| 12-10 | 60 | 155 | 270 | 295 |
| 14-4 | 45 | — | — | — |
| 14-5 | 40 | 92 | 184 | 273 |
| 14-12 | 43 | 90 | — | — |
| 14-15 | 17 | 110 | 155 | 234 |
| 14-19 | 30 | 165 | 315 | — |
| 16-8 | 54 | 152 | 180 | 331 |

| Insert Arrangement | Position (Degrees) | | | |
|--------------------|--------------------|-----|-----|-----|
| | W | X | Y | Z |
| 16-21 | — | — | — | — |
| 16-26 | 60 | — | 275 | 338 |
| 18-11 | 62 | 119 | 241 | 340 |
| 18-32 | 85 | 138 | 222 | 265 |
| 20-16 | 238 | 318 | 333 | 347 |
| 20-39 | 63 | 144 | 252 | 333 |
| 20-41 | 45 | 126 | 225 | — |
| 22-21 | 16 | 135 | 175 | 349 |
| 22-12 | — | — | — | — |
| 22-41 | 39 | — | — | — |
| 22-55 | 30 | 142 | 226 | 314 |
| 24-61 | 90 | 180 | 270 | 324 |

See page 40 for insert arrangements and back cover for configuration sheet.



DEUTSCH FDBA Series Filter Connectors

Insert Arrangements

- Filter Connector Series: FDBA
- Industry Specification: MIL-C-26482
- Insert Arrangement Specification: MIL-STD-1669

| Shell Size | Arrangement | Contact Size and Type | | |
|------------|-------------|-----------------------|----|----|
| | | 20 | 16 | 12 |
| 8 | 08-3A/0898 | 3 | — | — |
| | 08-33 | 3 | — | — |
| 10 | 10-06 | 6 | — | — |
| | 12-03 | — | 3 | — |
| 12 | 12-08 | 8 | — | — |
| | 12-10 | 10 | — | — |
| | 14-4 | — | — | 4 |
| 14 | 14-5 | — | 5 | — |
| | 14-12 | 8 | 4 | — |
| | 14-15 | 14 | 1 | — |
| | 14-19 | 19 | — | — |
| | 16-08 | — | 8 | — |
| 16 | 16-21 | 26 | — | — |
| | 16-26 | — | 11 | — |
| | 18-11 | — | 11 | — |
| 18 | 18-32 | 32 | — | — |
| | 20-16 | — | 16 | — |
| 20 | 20-39 | 37 | 2 | — |
| | 20-41 | 41 | — | — |
| | 22-12 | — | — | 12 |
| 22 | 22-21 | — | 21 | — |
| | 22-41 | 27 | 14 | — |
| | 22-55 | 55 | — | — |
| 24 | 24-61 | 61 | — | — |



DEUTSCH 983 Series Filter Connectors

MIL-DTL-83723 SERIES III



DEUTSCH 983 Series Connectors are MIL-DTL-83723 Series III style connectors meeting ESC10, ESC15, and EN2997 standards. With medium-density insert arrangements, fine threaded coupling, and corrosion resistant stainless steel shells, they are designed for the harsh environments of engines. They offer different keying options.

SPECIFICATIONS

Environmental

- **Temperature Range:** -55°C to 125°C
- **Physical Shock:** Typical to EIA-364-27
- **Vibration:** Typical to EIA-364-28
- **Fungus Resistance:** Based on MIL-STD-810
- **Fluid Immersion:** Typically tested to EIA-364-10
- **Salt Spray:** Typically based on EIA/ECA-364-26
- **Humidity:** Typically EIA-364-31 test method IV
- **Durability:** 500 cycles per MIL-DTL-83723

Electrical

- **Grounded Line Resistance (Typ.):** 15 mΩ
- **Insulation Resistance (Typ.):** >5 GΩ
- **Dielectric Withstand (Typ.):** <5 μA
- **DWV:** up to 2000 VDC
- **Working Voltage:** up to 2000 VDC
- **Typical Test Specifications Used:**
MIL-STD-810: Test Method Standard
MIL-STD-202: Electrical & Electronic Component Parts
RTCA DO-160: Test Procedures for Airborne Equipment
EIA-364: Electrical Connector & Socket Test Procedures

Filtering

- **Capacitance Range:** 20 pF to 4 μF
- **Capacitance Tolerance:** Typically 20%
- **Unfiltered Line Cap (Typ.):** 15 pF
- **Filtering Topologies:** L, C, LC, CL, Pi, T, Double T

Transient protection available as per RTCA Publication DO 160 (see page 55).

MATING COMPATIBILITY

- MIL-DTL-83723 Series III connectors
- ESC10 and ESC15 Connectors

RUGGED

- Designed specifically for engines
- Antivibration screw coupling connectors

RELIABLE

- RFI shell-to-shell continuity

VERSATILE

- Wide range of connector shell configurations
- Configurable filter topologies

DESIGNED FOR HARSH ENVIRONMENTS

- Vibration and shock
- Temperature extremes
- High humidity
- Altitude
- Salt spray



DEUTSCH 983 Series Filter Connectors

MIL-DTL-83723 SERIES III

Jam Nut Receptacles

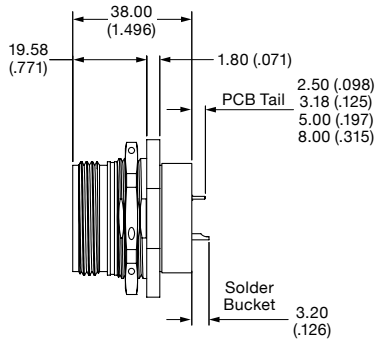

Single Flange

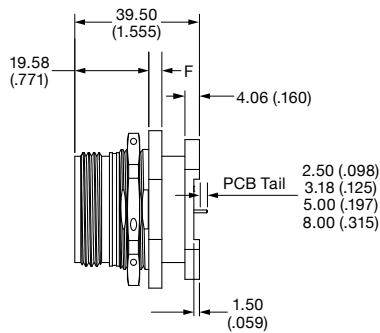

Double Flange

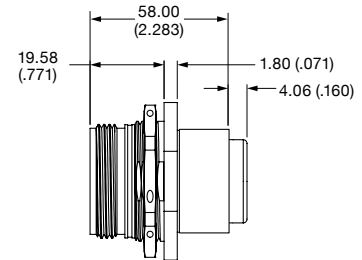

Single Flange, Crimp Contacts

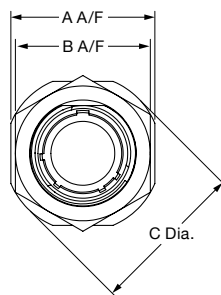

Front View

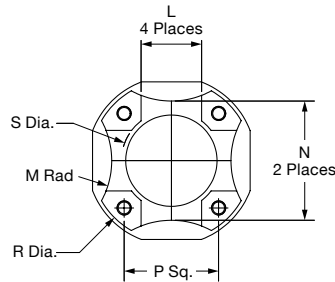

Double Flange Footprint

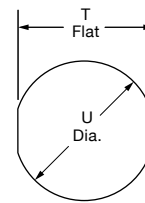

Recommended Panel Cutout

| Shell Size | A A/F Max. | B A/F Max. | C Dia. Max. | F | L Ref. | M Rad Ref. | N Ref. | P Sq. | R Dia. | S Dia. | Mounting Dims | |
|------------|------------------|------------------|------------------|-----------------|------------------|------------------|------------------|------------------|------------------|------------------|------------------|------------------|
| | | | | | | | | | | | T Flat | U Dia. |
| 8 | 24.89 (0.980) | 21.06 (0.829) | 27.38 (1.078) | | 8.00 (0.315) | 9.00 (0.354) | 15.50 (0.610) | 14.00 (0.551) | 27.06 (1.065) | 14.34 (0.565) | 15.50 (0.610) | 16.26 (0.640) |
| 10 | 28.04 (1.104) | 24.23 (0.953) | 30.28 (1.192) | | 8.00 (0.315) | 9.00 (0.354) | 15.50 (0.610) | 14.00 (0.551) | 27.06 (1.065) | 14.34 (0.565) | 18.67 (0.735) | 19.43 (0.765) |
| 12 | 32.79 (1.291) | 29.01 (1.142) | 35.05 (1.380) | | 8.00 (0.315) | 12.00 (0.472) | 18.65 (0.734) | 17.00 (0.669) | 32.06 (1.262) | 17.42 (0.686) | 23.42 (0.922) | 24.18 (0.952) |
| 14 | 35.33 (1.391) | 30.61 (1.205) | 38.51 (1.516) | 2.46 (0.097) | 12.00 (0.472) | 18.00 (0.709) | 22.00 (0.866) | 19.00 (0.748) | 35.06 (1.380) | 20.72 (0.816) | 25.02 (0.985) | 25.78 (1.015) |
| 16 | 38.51 (1.516) | 33.76 (1.329) | 41.68 (1.641) | | 12.00 (0.472) | 20.00 (0.787) | 25.25 (0.994) | 22.00 (0.866) | 39.06 (1.538) | 23.89 (0.941) | 28.20 (1.110) | 28.96 (1.140) |
| 18 | 41.68 (1.641) | 36.96 (1.455) | 44.86 (1.759) | | 16.00 (0.630) | 22.00 (0.866) | 28.40 (1.118) | 25.00 (0.984) | 42.06 (1.656) | 26.43 (1.041) | 31.25 (1.230) | 32.13 (1.265) |
| 20 | 44.86 (1.759) | 40.11 (1.579) | 49.63 (1.954) | | 16.00 (0.630) | 22.00 (0.866) | 31.55 (1.242) | 27.00 (1.063) | 45.06 (1.774) | 29.58 (1.165) | 34.42 (1.355) | 35.31 (1.390) |
| 22 | 49.63 (1.954) | 43.31 (1.705) | 52.78 (2.078) | | 16.00 (0.630) | 22.00 (0.866) | 34.50 (1.358) | 29.00 (1.142) | 48.06 (1.892) | 32.76 (1.290) | 37.59 (1.480) | 38.48 (1.515) |
| 24 | 52.81 (2.079) | 46.46 (1.829) | 55.42 (2.182) | 3.25 (0.128) | 16.00 (0.630) | 24.00 (0.945) | 37.30 (1.469) | 31.00 (1.221) | 51.06 (2.010) | 35.83 (1.411) | 40.77 (1.605) | 41.65 (1.640) |
| 28 | 59.21 (2.331) | 54.41 (2.080) | 61.82 (2.434) | | 18.00 (0.709) | 24.00 (0.945) | 44.50 (1.752) | 35.00 (1.378) | 56.06 (2.207) | 39.01 (1.536) | 47.14 (1.856) | 48.01 (1.890) |

See page 45 for insert arrangements and back cover for configuration sheet.



DEUTSCH 983 Series Filter Connectors

MIL-DTL-83723 SERIES III

Square Flange Receptacles

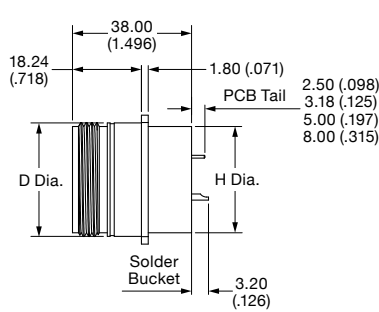

Single Flange

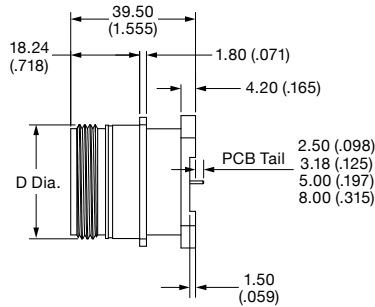

Double Flange

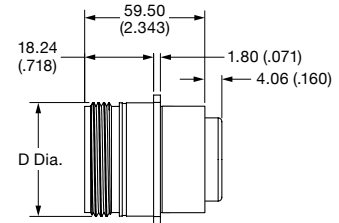

Single Flange, Crimp Contacts

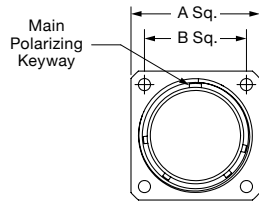

Front View

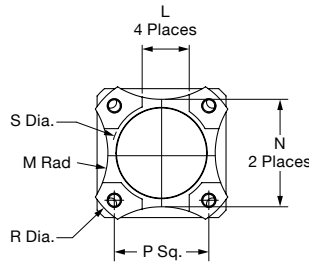

Double Flange Footprint

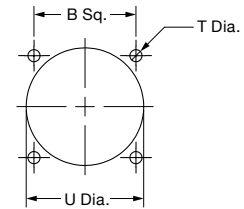

Square Flange Mounting

| Shell Size | A Sq. Max. | B Sq. | D Dia. Max. | H Dia. Max. | L Ref. | M Rad Ref. | N Ref. | P Sq. | R Dia. | S Dia. | Mounting Holes | |
|------------|------------------|------------------|------------------|------------------|------------------|------------------|------------------|------------------|------------------|------------------|------------------|------------------|
| | | | | | | | | | | | T Dia. | U Dia. |
| 8 | 20.75 (0.817) | 15.09 (0.594) | 14.27 (0.562) | 12.70 (0.500) | 8.00 (0.315) | 9.00 (0.354) | 15.50 (0.610) | 14.00 (0.551) | 27.06 (1.065) | 14.34 (0.565) | 3.05 (0.120) | 15.80 (0.622) |
| 10 | 23.93 (0.942) | 18.26 (0.719) | 17.47 (0.688) | 15.88 (0.625) | 8.00 (0.315) | 9.00 (0.354) | 15.50 (0.610) | 14.00 (0.551) | 27.06 (1.065) | 14.34 (0.565) | | 18.70 (0.736) |
| 12 | 26.32 (1.036) | 20.62 (0.812) | 22.22 (0.875) | 19.05 (0.750) | 8.00 (0.315) | 12.00 (0.472) | 18.65 (0.734) | 17.00 (0.669) | 32.06 (1.262) | 17.42 (0.686) | | 23.40 (0.921) |
| 14 | 28.71 (1.130) | 23.01 (0.906) | 23.82 (0.938) | 22.23 (0.875) | 12.00 (0.472) | 18.00 (0.709) | 22.00 (0.866) | 19.00 (0.748) | 35.06 (1.380) | 20.72 (0.816) | | 24.90 (0.980) |
| 16 | 31.88 (1.255) | 24.61 (0.969) | 26.97 (1.062) | 25.40 (1.000) | 12.00 (0.472) | 20.00 (0.787) | 25.25 (0.994) | 22.00 (0.866) | 39.06 (1.538) | 23.89 (0.941) | | 28.30 (1.114) |
| 18 | 34.24 (1.348) | 26.97 (1.062) | 30.18 (1.188) | 26.97 (1.062) | 16.00 (0.630) | 22.00 (0.866) | 28.40 (1.118) | 25.00 (0.984) | 42.06 (1.656) | 26.43 (1.041) | | 31.10 (1.224) |
| 20 | 36.63 (1.442) | 29.36 (1.156) | 33.32 (1.312) | 30.18 (1.187) | 16.00 (0.630) | 22.00 (0.866) | 31.55 (1.242) | 27.00 (1.063) | 45.06 (1.774) | 29.58 (1.165) | | 34.50 (1.358) |
| 22 | 39.80 (1.567) | 31.75 (1.250) | 36.53 (1.438) | 33.32 (1.312) | 16.00 (0.630) | 22.00 (0.866) | 34.50 (1.358) | 29.00 (1.142) | 48.06 (1.892) | 32.76 (1.290) | 37.50 (1.476) | |
| 24 | 43.39 (1.708) | 34.92 (1.375) | 39.67 (1.562) | 36.50 (1.437) | 16.00 (0.630) | 24.00 (0.945) | 37.30 (1.469) | 31.00 (1.221) | 51.06 (2.010) | 35.83 (1.411) | 3.80 (0.150) | 40.60 (1.598) |
| 28 | 50.93 (2.005) | 39.67 (1.562) | 46.02 (1.812) | 44.45 (1.750) | 18.00 (0.709) | 24.00 (0.945) | 44.50 (1.752) | 35.00 (1.378) | 56.06 (2.207) | 39.01 (1.536) | | 48.00 (1.890) |

See page 45 for insert arrangements and back cover for configuration sheet.



DEUTSCH 983 Series Filter Connectors

MIL-DTL-83723 SERIES III

Plugs

| Shell Size | A Dia. Max | W Thread Class 2A |
|------------|------------------|-------------------|
| 8 | 21.30 (0.838) | 0.5000-20 UNF |
| 10 | 24.89 (0.980) | 0.6250-24 UNEF |
| 12 | 29.59 (1.165) | 0.7500-20 UNEF |
| 14 | 31.24 (1.230) | 0.8750-20 UNEF |
| 16 | 34.42 (1.355) | 1.0000-20 UNEF |
| 18 | 37.34 (1.470) | 1.0625-18 UNEF |
| 20 | 41.91 (1.650) | 1.1875-18 UNEF |
| 22 | 44.07 (1.735) | 1.3125-18 UNEF |
| 24 | 47.24 (1.860) | 1.4375-18 UNEF |
| 28 | 55.24 (2.175) | 1.7500-18 UNS |

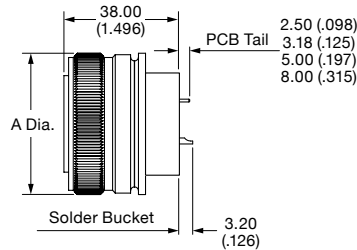

PCB/Solder Bucket Contacts

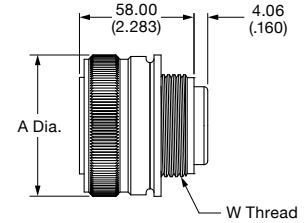

Crimp Contacts

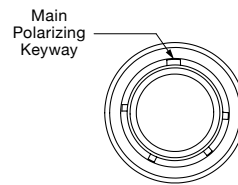

Front View

Keying Options

(Plug Mating Face Shown)

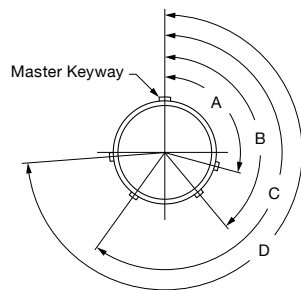

| Key/Keyway | Keyway (In Degrees) | | | | | | | | | | | |
|------------|---------------------|-----|-----|-----|---------|-----|-----|-----|---------------|-----|-----|-----|
| | Size 8 | | | | Size 10 | | | | Size 12 to 28 | | | |
| | A | B | C | D | A | B | C | D | A | B | C | D |
| N (Normal) | 105 | 140 | 215 | 265 | 105 | 140 | 215 | 265 | 105 | 140 | 215 | 265 |
| 6 | 102 | 132 | 248 | 320 | 102 | 132 | 248 | 320 | 18 | 148 | 192 | 259 |
| 7 | 80 | 118 | 230 | 312 | 80 | 118 | 230 | 312 | 92 | 152 | 222 | 342 |
| 8 | 35 | 140 | 205 | 275 | 35 | 140 | 205 | 275 | 84 | 152 | 204 | 334 |
| 9 | 64 | 155 | 234 | 304 | 64 | 155 | 234 | 304 | 24 | 135 | 199 | 240 |
| Y | — | — | — | — | 25 | 115 | 220 | 270 | 98 | 152 | 268 | 338 |

See page 45 for insert arrangements and back cover for configuration sheet.



DEUTSCH 983 Series Filter Connectors MIL-DTL-83723 SERIES III

Insert Arrangements

- Filter Connector Series: 983
- Industry Specification: MIL-DTL-83723 Series III
- Insert Arrangement Specification: MIL-STD-1554

| Shell Size | Arrangement | Contact Size and Type | | | |
|------------|-------------|-----------------------|----|----|---------|
| | | 20 | 16 | 12 | Quadrax |
| 8 | 08-03 | 3 | — | — | — |
| | 08-98 | 3 | — | — | — |
| 10 | 10-05 | 5 | — | — | — |
| | 10-06 | 6 | — | — | — |
| 12 | 12-03 | — | 3 | — | — |
| | 12-12 | 12 | — | — | — |
| 14 | 14-04 | — | — | 4 | — |
| | 14-07 | — | 7 | — | — |
| | 14-12 | 9 | 3 | — | — |
| | 14-15 | 15 | — | — | — |
| 16 | 16-10 | — | 10 | — | — |
| | 16-24 | 24 | — | — | — |
| 18 | 18-02 | — | — | — | 2 |
| | 18-08 | — | — | 8 | — |
| | 18-14 | — | 14 | — | — |
| | 18-31 | 31 | — | — | — |
| 20 | 20-04 | — | — | — | 4 |
| | 20-16 | — | 16 | — | — |
| | 20-25 | 19 | — | 6 | — |
| | 20-28 | 24 | — | 4 | — |
| | 20-39 | 37 | 2 | — | — |
| | 20-41 | 41 | — | — | — |
| 22 | 22-12 | — | — | 12 | — |
| | 22-19 | — | 19 | — | — |
| | 22-30 | 24 | — | 6 | — |
| | 22-32 | 26 | — | 6 | — |
| | 22-39 | 27 | 12 | — | — |
| | 22-55 | 55 | — | — | — |
| 24 | 24-30 | — | 30 | — | — |
| | 24-57 | 55 | — | 2 | — |
| | 24-61 | 61 | — | — | — |
| | 28-06 | — | — | — | 6 |
| | 28-42 | — | 42 | — | — |



DEUTSCH 984 Series Filter Connectors

MIL-DTL-83723 SERIES III



DEUTSCH 984 Series connectors are intermateable and interchangeable with ESC11 and ESC16 connectors. With medium-density insert arrangements, fine threaded coupling, and corrosion resistant stainless steel shells, they are designed for the harsh environments of engines. They offer different keying options.

SPECIFICATIONS

Environmental

- **Temperature Range:** -55°C to 125°C
- **Physical Shock:** Typical to EIA-364-27
- **Vibration:** Typical to EIA-364-28
- **Fungus Resistance:** Based on MIL-STD-810
- **Fluid Immersion:** Typically tested to EIA-364-10
- **Salt Spray:** Typically based on EIA/ECA-364-26
- **Humidity:** Typically EIA-364-31 test method IV
- **Durability:** 500 cycles per MIL-DTL-83723

Electrical

- **Grounded Line Resistance (Typ.):** 15 mΩ
- **Insulation Resistance (Typ.):** >5 GΩ
- **Dielectric Withstand (Typ.):** <5 μA
- **DWV:** up to 2000 VDC
- **Working Voltage:** up to 2000 VDC
- **Typical Test Specifications Used:**
 - MIL-STD-810: Test Method Standard
 - MIL-STD-202: Electrical & Electronic Component Parts
 - RTCA DO-160: Test Procedures for Airborne Equipment
 - EIA-364: Electrical Connector & Socket Test Procedures

Filtering

- **Capacitance Range:** 20 pF to 4 μF
- **Capacitance Tolerance:** Typically 20%
- **Unfiltered Line Cap (Typ.):** 15 pF
- **Filtering Topologies:** L, C, LC, CL, Pi, T, Double T

Transient protection available as per RTCA Publication DO 160 (see page 55).

MATING COMPATIBILITY

- MIL-DTL-83723 Series 3 connectors
- ESC11 and ESC16 Connectors

RUGGED

- Designed specifically for engines
- Antivibration screw coupling connectors

RELIABLE

- 100% scoop proof
- RFI shell-to-shell continuity

VERSATILE

- Wide range of connector shell configurations
- Configurable filter topologies

DESIGNED FOR HARSH ENVIRONMENTS

- Vibration and shock
- Temperature extremes
- High humidity
- Altitude
- Salt spray



DEUTSCH 984 Series Filter Connectors

MIL-DTL-83723 SERIES III

Square Flange Receptacles

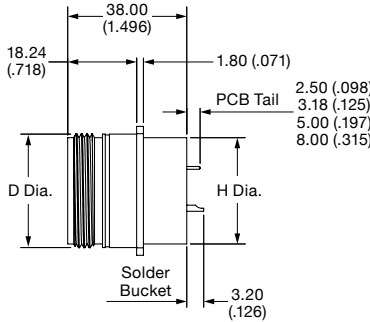

Single Flange

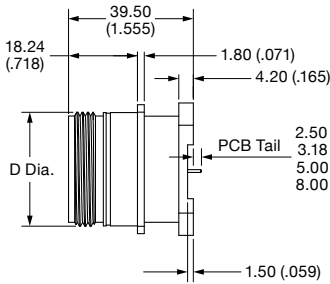

Double Flange

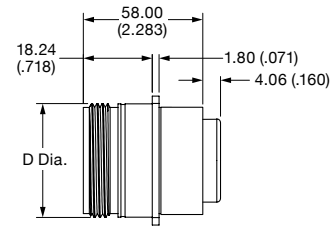

Single Flange, Crimp Contacts

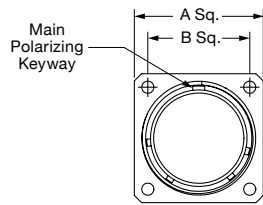

Front View

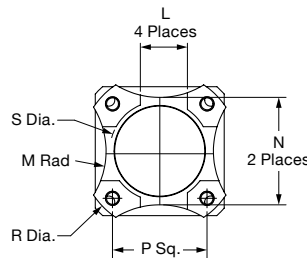

Double Flange Footprint

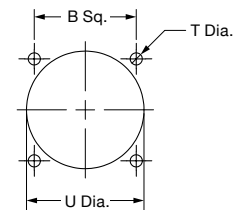

Square Flange Mounting

| Shell Size | A Sq. Max. | B Sq. | D Dia. Max. | H Dia. Max. | L Ref. | M Rad Ref. | N Ref. | P Sq. | R Dia. | S Dia. | Mounting Holes | |
|------------|---------------|---------------|---------------|---------------|---------------|---------------|---------------|---------------|---------------|---------------|----------------|---------------|
| | | | | | | | | | | | T Dia. | U Dia. |
| 8 | 20.75 (0.817) | 15.09 (0.594) | 14.27 (0.562) | 12.70 (0.500) | 8.00 (0.315) | 9.00 (0.354) | 15.50 (0.610) | 14.00 (0.551) | 27.06 (1.065) | 14.34 (0.565) | | 15.80 (0.622) |
| 10 | 23.93 (0.942) | 18.26 (0.719) | 17.47 (0.688) | 15.88 (0.625) | 8.00 (0.315) | 9.00 (0.354) | 15.50 (0.610) | 14.00 (0.551) | 27.06 (1.065) | 14.34 (0.565) | | 18.70 (0.736) |
| 12 | 26.32 (1.036) | 20.62 (0.812) | 22.22 (0.875) | 19.05 (0.750) | 8.00 (0.315) | 12.00 (0.472) | 18.65 (0.734) | 17.00 (0.669) | 32.06 (1.262) | 17.42 (0.686) | | 23.40 (0.921) |
| 14 | 28.71 (1.130) | 23.01 (0.906) | 23.82 (0.938) | 22.23 (0.875) | 12.00 (0.472) | 18.00 (0.709) | 22.00 (0.866) | 19.00 (0.748) | 35.06 (1.380) | 20.72 (0.816) | 3.05 (0.120) | 24.90 (0.980) |
| 16 | 31.88 (1.255) | 24.61 (0.969) | 26.97 (1.062) | 25.40 (1.000) | 12.00 (0.472) | 20.00 (0.787) | 25.25 (0.994) | 22.00 (0.866) | 39.06 (1.538) | 23.89 (0.941) | | 28.30 (1.114) |
| 18 | 34.24 (1.348) | 26.97 (1.062) | 30.18 (1.188) | 26.97 (1.062) | 16.00 (0.630) | 22.00 (0.866) | 28.40 (1.118) | 25.00 (0.984) | 42.06 (1.656) | 26.43 (1.041) | | 31.10 (1.224) |
| 20 | 36.63 (1.442) | 29.36 (1.156) | 33.32 (1.312) | 30.18 (1.187) | 16.00 (0.630) | 22.00 (0.866) | 31.55 (1.242) | 27.00 (1.063) | 45.06 (1.774) | 29.58 (1.165) | | 34.50 (1.358) |
| 22 | 39.80 (1.567) | 31.75 (1.250) | 36.53 (1.438) | 33.32 (1.312) | 16.00 (0.630) | 22.00 (0.866) | 34.50 (1.358) | 29.00 (1.142) | 48.06 (1.892) | 32.76 (1.290) | | 37.50 (1.476) |
| 24 | 43.39 (1.708) | 34.92 (1.375) | 39.67 (1.562) | 36.53 (1.437) | 16.00 (0.630) | 24.00 (0.945) | 37.30 (1.469) | 31.00 (1.221) | 51.06 (2.010) | 35.83 (1.411) | 3.80 (0.150) | 40.60 (1.598) |
| 28 | 50.93 (2.005) | 39.67 (1.562) | 46.02 (1.812) | 44.45 (1.750) | 18.00 (0.709) | 24.00 (0.945) | 44.50 (1.752) | 35.00 (1.378) | 56.06 (2.207) | 39.01 (1.536) | | 48.00 (1.890) |

See page 48 for insert arrangements and back cover for configuration sheet.



DEUTSCH 984 Series Filter Connectors

MIL-DTL-83723 SERIES III

Plug Connectors

| Shell Size | A Dia. Max. | W Thread Class 2B |
|------------|------------------|-------------------|
| 8 | 21.30 (0.838) | 0.5000-20 UNF |
| 10 | 24.89 (0.980) | 0.6250-24 UNEF |
| 12 | 29.59 (1.165) | 0.7500-20 UNEF |
| 14 | 31.24 (1.230) | 0.8750-20 UNEF |
| 16 | 34.42 (1.355) | 1.0000-20 UNEF |
| 18 | 37.34 (1.470) | 1.0625-18 UNEF |
| 20 | 41.91 (1.650) | 1.1875-18 UNEF |
| 22 | 44.07 (1.735) | 1.3125-18 UNEF |
| 24 | 47.24 (1.860) | 1.4375-18 UNEF |
| 28 | 55.24 (2.175) | 1.7500-18 UNS |

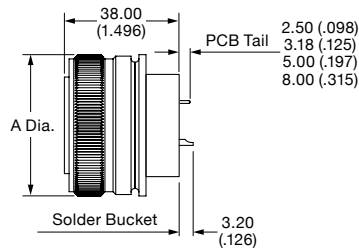

PCB/Solder Bucket Contacts

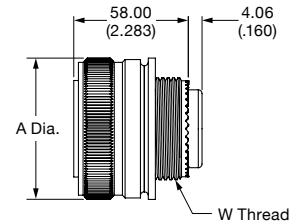

Crimp Contacts

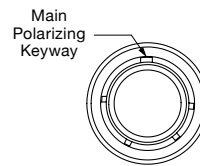

Front View

Insert Arrangements

- Filter Connector Series: 984
- Industry Specification: EN4067
- Insert Arrangement Specification: MIL-STD-1554

| Shell Size | Arrangement | Size 20 Contacts |
|------------|-------------|------------------|
| 14 | 14-15 | 15 |
| 16 | 16-24 | 24 |
| 18 | 18-31 | 31 |
| 20 | 20-41 | 41 |
| 22 | 22-55 | 55 |
| 24 | 24-61 | 61 |

Keying Options

(Plug Mating Face Shown)

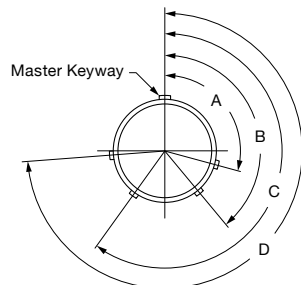

| Key/Keyway | Keyway (In Degrees) | | | | | | | | | | | |
|------------|---------------------|-----|-----|-----|---------|-----|-----|-----|---------------|-----|-----|-----|
| | Size 8 | | | | Size 10 | | | | Size 12 to 28 | | | |
| | A | B | C | D | A | B | C | D | A | B | C | D |
| N (Normal) | 105 | 140 | 215 | 265 | 105 | 140 | 215 | 265 | 105 | 140 | 215 | 265 |
| 6 | 102 | 132 | 248 | 320 | 102 | 132 | 248 | 320 | 18 | 148 | 192 | 259 |
| 7 | 80 | 118 | 230 | 312 | 80 | 118 | 230 | 312 | 92 | 152 | 222 | 342 |
| 8 | 35 | 140 | 205 | 275 | 35 | 140 | 205 | 275 | 84 | 152 | 204 | 334 |
| 9 | 64 | 155 | 234 | 304 | 64 | 155 | 234 | 304 | 24 | 135 | 199 | 240 |
| Y | — | — | — | — | 25 | 115 | 220 | 270 | 98 | 152 | 268 | 338 |



Additional Filter Connector Capabilities

Additional Connector Families

Consult with TE for filtering options available for a variety of other TE connector families. The following are examples.



ARINC 600 Connectors

ARINC 600 connectors are the standard rack and panel connectors for aircraft and military ground vehicle applications. They are available in shell sizes 1, 2, and 3, with a comprehensive range of insert options for EMI and transient protection, various platings, and numerous keying options.



MIL-DTL-5015 Connectors

The DEUTSCH HAN connector is a cylindrical, multicontact environmental connector designed to meet and exceed the requirements of MIL-DTL-5015. Various medium and low-density insert arrangements are available for EMI and transient protection. They use a screw coupling and feature various plating options and five different keying options.



MIL-DTL-81511 Connectors

The DEUTSCH LL series connector is the MIL-DTL-81511 style, which has high-density inserts and bayonet coupling. The LL series are available in two versions: a long scoop-proof shell and a short shell that is scoop proof only when pin contacts are used in the receptacle connector. The series offers various plating options and six different keying options.



VG95234 Connectors

VG95234 connectors are derived from the MIL-DTL-5015, but with a reverse bayonet coupling mechanism. Various medium and low-density insert arrangements are available for EMI and transient protection. The connectors feature a full range of plating options and five different keying options.



VG95328 Connectors

Based on MIL-DTL-26482 Series 1, VG95328 connectors have the same insert arrangements, shell dimensions and performance. The three-point bayonet coupling mechanism provides easy mating and positive locking. Various medium-density insert arrangements are available for EMI and transient protection, along with a full range of plating options and five different keying options.



Additional Filter Connector Capabilities

Additional Connector Styles



Adapter

This solution is formed by placing the filter components between a plug and receptacle, and housing the entire package in one shell. The adaptor then connects between the system's existing plug and receptacle. Therefore, it is particularly suited to retrofit/upgrade applications where changing either the free plug or chassis receptacle would create technical and logistical difficulties.



Feedthrough

Filter components can be mounted in a feedthrough style. This allows either direct PCB mounting, wire termination to solder buckets, crimp contacts, or crimp eyelet connections at both sides of a bulkhead, for example, between clean and dirty areas of a black box. Both EMI and transient protection can be provided.



Hermetic Filter Connectors

Filtered hermetic connectors use glass-to-metal sealing technology. They are ideally suited for applications where you need to keep fluid and harsh materials or high pressure in one area. Filtering components can be fitted within the shell of the hermetic connector to provide protection capable of withstanding harsh environments. Hermetic connectors are available with various medium and low-density insert arrangements, platings, and keying options for EMI and transient protection.



Headers

Using a header to install a filtered connector onto a PCB can save time and processing costs. Headers with press fit, compliant pins, or solder mount contacts can be supplied in many configurations. For installation, once the header is installed in the PCB, the filter connector will mate directly onto the header, providing electrical continuity and sealing prior to final assembly of the equipment.



Filtering Technologies

EMI FILTER CONNECTORS—PLANAR ARRAY TECHNOLOGY

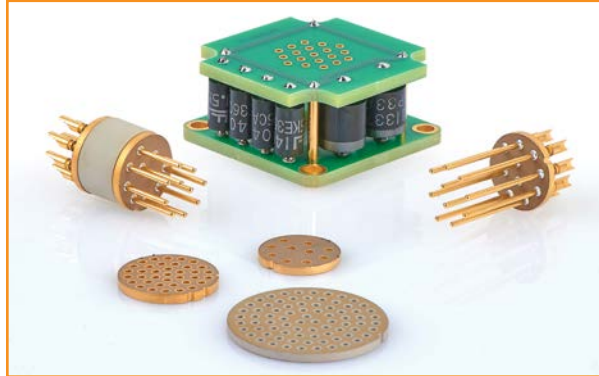

While the first filter connectors used bulky tubular filters, planar arrays today are the favored technology because of their performance, ease of manufacturing, durability, and costs. An array can be built into the connectors to save space and simplify application. Surface-mount filtering is also used in less-demanding, cost-sensitive applications.

The filter array provides the required capacitance for each through pin and the inductance is provided by ferrite beads suitably positioned. Pi filter configurations require two planar arrays.

The ground path for each capacitor is provided through the planar array and makes contact with the shell of the connector via a compliant grounding spring. Within limits, each filtered contact can have a different value of capacitance from its neighbor, providing a very flexible degree of customization.

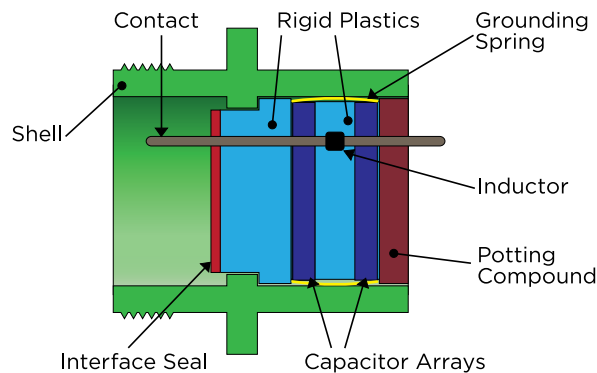

Planar Filter Connector Advantages

- Compact design
- Very rugged. Suitable for hostile environments
- Good resistance to high voltage spikes
- Cost effective, particularly at higher production volumes
- Dielectric withstand voltage typically 500 Vdc, but can be specified up to 3 kV in some applications

Surface Mount Filtering

For some applications, using surface-mount components within the connector can provide a more cost-effective solution. SMT can also be more accommodating to changes in the capacitance footprint.

SMT is well suited to high-volume applications, such as aerospace, land, and industrial uses, where conditions are less demanding.

SMT components are mounted on a PCB that fits over the contacts. The board-mount components can be located between contacts or around the periphery, depending on the contact density and the application. While several methods are used to provide ground path to the connector shell, generally a compliant spring is used to ensure long-term reliability.

Surface Mount Filter Connector Advantages

- Cost effective solution, particularly in less demanding applications
- Shorter lead-time
- Very accommodating to changes in capacitor footprint
- Wide spread of filter values can be mixed



Filtering Technologies

| Source Impedance | Filter Type | Load Impedance | Construction |
|------------------|------------------------|----------------|--|
| Low | <p>L Filter</p> | Low | <p>Inductor</p> |
| High | <p>C Filter</p> | High | <p>Capacitor Array</p> |
| Low | <p>LC Filter</p> | High | <p>Inductor</p> <p>Capacitor Array</p> |
| Low | <p>T Filter</p> | Low | <p>Inductors</p> <p>Capacitor Array</p> |
| High | <p>Pi Filter</p> | High | <p>Inductor</p> <p>Capacitor Arrays</p> |
| Low | <p>Double T Filter</p> | Low | <p>Inductors</p> <p>Capacitor Arrays</p> |



Filtering Technologies

General Specifications

- **Temperature Limits:** -55°C to +125°C

Capacitance:

- **Minimum per line:** Typically 50 pF
- **Maximum per line:** Typically up to 1 μ F (Higher available for specific applications)
- **Unfiltered line:** 100 pF max (Lower available on request)

Working Voltage:

- **DC:** Up to 2 kV (depending on capacitance)
- **AC:** Up to 1 kV peak (depending on capacitance and specific requirements)
- **Standard Capacitance Tolerance:** 20%
- **Dielectric Material:** COG or X7R (application specific)
- **Insulation Resistance:** Up to 5 G Ω (greater available if required)
- **Dielectric Withstand Voltage:** Typically 500 VDC (can be up to 3000 VDC)
- **Ground Path Resistance:** 15 m Ω typ (pin to shell)

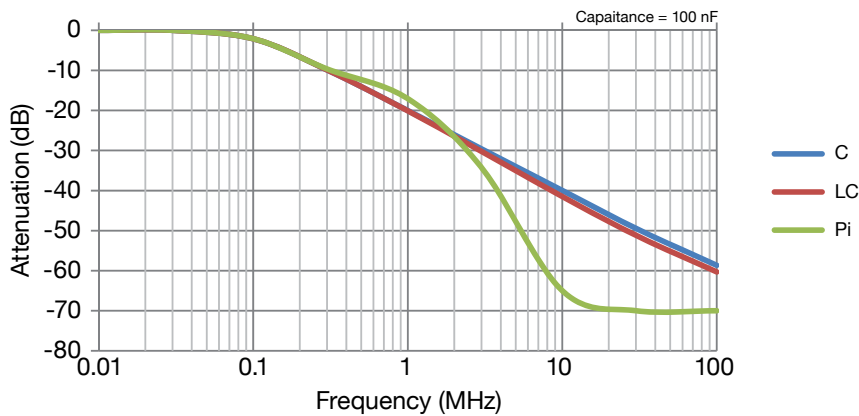

Attenuation by Filter Type

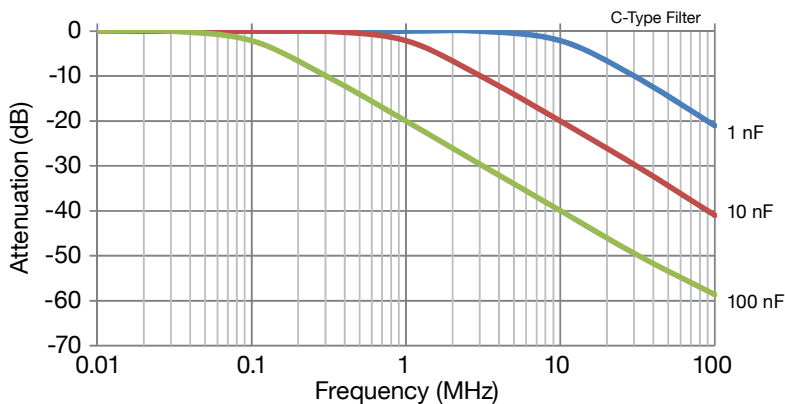

Attenuation by Capacitance (C-Type Filter)



Filtering Technologies

Attenuation (dBs) by Frequency and Filter Topology

| Capacitance | 30 kHz | | 100 kHz | | 300 kHz | | 1 MHz | | 3 MHz | | | 10 MHz | | | 30 MHz | | | 100 MHz | | |
|-------------|-----------|----|-----------|----|-----------|----|-----------|----|-------|--------|----|--------|-------|----|--------|-------|-----|---------|-------|-----|
| | C, LC, CL | PI | C, LC, CL | PI | C, LC, CL | PI | C, LC, CL | PI | C | LC, CL | PI | C | LC/CL | PI | C | LC/CL | PI | C | LC/CL | PI |
| 50 pF | | | | | | | | | | | | | | | | 1 | N/A | 1 | 2 | N/A |
| 100 pF | | | | | | | | | | | | | | | | | | 2 | 3 | 3 |
| 200 pF | | | | | | | | | | | | | | | 1 | 1 | 1 | 7 | 8 | 8 |
| 250 pF | | | | | | | | | | | | | | | 1 | 1 | 1 | 8 | 10 | 10 |
| 500 pF | | | | | | | | | | | | | | | 4 | 5 | 6 | 14 | 15 | 17 |
| 1 nF | | | | | | | | | | | | | | | 10 | 10 | 11 | 21 | 22 | 27 |
| 1.25 nF | | | | | | | | | | | | 3 | 3 | 3 | 11 | 13 | 13 | 22 | 24 | 30 |
| 1.65 nF | | | | | | | | | | | | 5 | 5 | 5 | 14 | 15 | 16 | 25 | 27 | 34 |
| 2.0 nF | | | | | | | | | 1 | 1 | 1 | 6 | 7 | 7 | 15 | 16 | 18 | 26 | 28 | 37 |
| 2.5 nF | | | | | | | | | 1 | 1 | 1 | 9 | 10 | 11 | 17 | 19 | 21 | 29 | 31 | 40 |
| 3.25 nF | | | | | | | | | 2 | 2 | 2 | 10 | 10 | 10 | 19 | 20 | 24 | 30 | 32 | 40 |
| 3.3 nF | | | | | | | | | 2 | 2 | 2 | 10 | 10 | 10 | 19 | 20 | 24 | 30 | 32 | 45 |
| 3.75 nF | | | | | | | | | 2 | 2 | 2 | 11 | 12 | 11 | 21 | 24 | 26 | 31 | 34 | 48 |
| 5 nF | | | | | | | | | 4 | 4 | 4 | 14 | 14 | 14 | 23 | 25 | 31 | 34 | 36 | 53 |
| 6.5 nF | | | | | | | 1 | 1 | 5 | 5 | 5 | 16 | 16 | 16 | 25 | 27 | 35 | 37 | 38 | 58 |
| 7.5 nF | | | | | | | 1 | 1 | 6 | 6 | 6 | 16 | 17 | 19 | 26 | 28 | 37 | 38 | 40 | 61 |
| 10 nF | | | | | | | 2 | 1 | 9 | 10 | 8 | 20 | 21 | 20 | 29 | 31 | 41 | 40 | 42 | 65 |
| 12.5 nF | | | | | | | 3 | 3 | 11 | 12 | 9 | 21 | 23 | 25 | 31 | 33 | 46 | 42 | 44 | 70 |
| 15 nF | | | | | | | 4 | 4 | 12 | 13 | 11 | 23 | 25 | 29 | 33 | 35 | 49 | 44 | 46 | 70 |
| 20 nF | | | | | 1 | 1 | 6 | 6 | 15 | 16 | 12 | 25 | 27 | 33 | 35 | 37 | 55 | 46 | 48 | 70 |
| 25 nF | | | | | 1 | 1 | 8 | 7 | 17 | 18 | 14 | 27 | 29 | 37 | 37 | 39 | 59 | 48 | 50 | 70 |
| 30 nF | | | | | 2 | 2 | 9 | 9 | 19 | 19 | 15 | 29 | 31 | 40 | 39 | 41 | 63 | 50 | 52 | 70 |
| 32.5 nF | | | | | 2 | 2 | 10 | 9 | 18 | 20 | 15 | 29 | 31 | 42 | 39 | 42 | 65 | 49 | 52 | 70 |
| 40 nF | | | | | 3 | 3 | 12 | 11 | 21 | 21 | 17 | 32 | 33 | 46 | 41 | 43 | 70 | 52 | 54 | 70 |
| 50 nF | | | | | 4 | 4 | 14 | 12 | 23 | 23 | 20 | 33 | 34 | 50 | 43 | 45 | 70 | 54 | 56 | 70 |
| 65 nF | | | 1 | 1 | 6 | 4 | 16 | 14 | 25 | 26 | 25 | 36 | 37 | 55 | 45 | 47 | 70 | 56 | 58 | 70 |
| 80 nF | | | 1 | 1 | 8 | 5 | 18 | 15 | 27 | 27 | 29 | 38 | 39 | 59 | 47 | 49 | 70 | 57 | 59 | 70 |
| 100 nF | | | 2 | 2 | 9 | 9 | 19 | 17 | 29 | 29 | 34 | 39 | 40 | 64 | 49 | 51 | 70 | 58 | 60 | 70 |
| 130 nF | | | 3 | 3 | 11 | 11 | 22 | 18 | 31 | 31 | 39 | 42 | 43 | 70 | 51 | 53 | 70 | 59 | 61 | 70 |
| 150 nF | | | 4 | 4 | 13 | 12 | 23 | 18 | 33 | 33 | 42 | 43 | 44 | 70 | 52 | 54 | 70 | 60 | 62 | 70 |
| 200 nF | 1 | 1 | 6 | 6 | 15 | 15 | 26 | 18 | 35 | 36 | 47 | 45 | 56 | 70 | 54 | 56 | 70 | 61 | 62 | 70 |
| 300 nF | 1 | 1 | 9 | 8 | 19 | 17 | 29 | 21 | 39 | 39 | 55 | 49 | 50 | 70 | 57 | 59 | 70 | 61 | 63 | 70 |

Please consult TE if alternative or extended attenuation requirements are needed.



Filtering Technologies

TRANSIENT PROTECTION

Transient protection counters high-voltage electromagnetic pulses (EMPs). This technology can be used independently or in conjunction with EMI filtering to provide maximum protection from a wide variety of interference sources. Like EMI filtering, transient protection can be incorporated within the connector. Transient protection protects against the downstream effects of:

- Electromagnetic Pulses (EMP)
- Lightning (LEMP)
- Electrostatic Discharges (ESD)
- High-Altitude Electromagnetic Pulses (HEMP)
- Nuclear Electromagnetic Pulses (NEMP)

Applications for EMP protection are similar to those for filter connectors, but also includes engine power and power distribution in military aircraft. Military ground vehicles are also important candidates. While there are several device types available to accomplish transient protection, the most popular is the transient voltage suppressor (TVS).

A TVS is a specialized Zener diode that limits voltage spikes to acceptable levels, thereby preventing damage to sensitive components. Metal-oxide varistors (MOVs) can also be considered for specific applications.

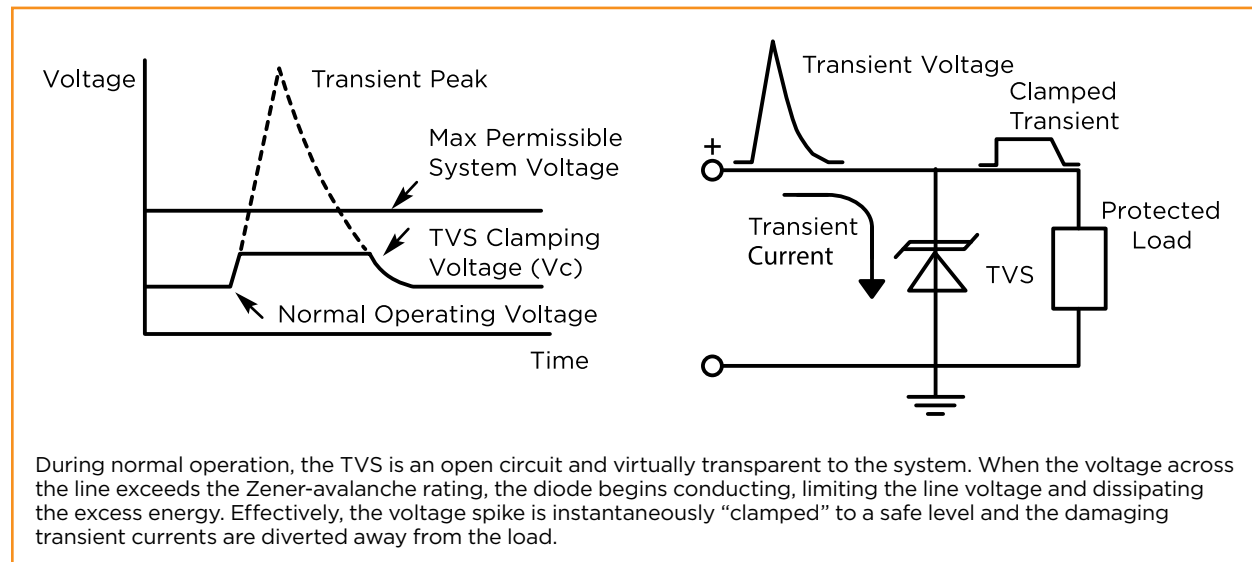

Transient Protection and I/O Connectors

The optimum location for protective devices is at the point of entry into a piece of equipment. This protects vulnerable downstream circuits from harmful voltage surges. Transient suppression devices clamp overvoltage surges to a safe level, with the energy from the surge dissipated within the devices as heat.

Specifying a Transient Waveform

It's recognized that transient waveforms will vary between equipment installations.

To help with this level of uncertainty, a pre-determined set of test waveforms has been defined to determine the ability of equipment to withstand transient events. These waveforms are defined in RTCA publication DO-160, along with selection guidelines for which waveform(s) apply to the equipment in question.

Specifying a TVS Diode

To correctly specify a TVS diode, several pieces of information are required, including transient voltages that need to be suppressed, maximum steady-state system



Filtering Technologies

voltage, and the operating temperature range. Steady-state system voltage will determine the stand-off voltage of the TVS diode. Temperature range will have an effect on both the breakdown voltage of the TVS diode, and the power rating required for the specified transient waveforms.

TVS diodes mainly have their power ratings specified for a 10/1000 μ s pulse; however, most transient voltages have waveforms that differ from this standard. The maximum transient current for a TVS diode can be scaled between waveforms.

Most TVS diode manufacturers provide guidance on re-rating TVS diodes, but TE can assist if required.

Common TVS Diode Package Sizes and Power Ratings

Transient suppression diodes are available in a range of stand-off voltages and power ratings, from multiple suppliers. Components are available in both surface mount & axial-leaded configurations. Common ranges are shown below; other configurations may be available for specific applications.

Typical TVS Diodes for Selected Signal/Transient Voltage Combinations

| Steady-State Voltage | Transient Voltage | Typical TVS Diode Part No. | TVS Diode Power Rating |
|----------------------|-----------------------------|----------------------------|------------------------|
| 5 VDC | DO-160, Waveform 3, Level 3 | P4KE6.8 | 400 W (see note) |
| | DO-160, Waveform 3, Level 4 | SA5.0 | 500W |
| | DO-160, Waveform 4, Level 3 | P4KE6.8 | 400 W (see note) |
| | DO-160, Waveform 4, Level 4 | 1.5KE6.8 | 1.5kW |
| 12 VDC | DO-160, Waveform 3, Level 3 | P4KE16 | 400 W (see note) |
| | DO-160, Waveform 3, Level 4 | 1.5KE15 | 1.5 kW |
| | DO-160, Waveform 4, Level 3 | SA12 | 500 W |
| | DO-160, Waveform 4, Level 4 | 5KP12 | 5 kW |
| 28V DC | DO-160, Waveform 3, Level 3 | SA33 | 500 W |
| | DO-160, Waveform 3, Level 4 | 1.5KE39 | 1.5 kW |
| | DO-160, Waveform 4, Level 3 | SA33 | 500 W |
| | DO-160, Waveform 4, Level 4 | 5KP33 | 5 kW |
| 115 VAC | DO-160, Waveform 3, Level 3 | 1.5KE200C | 1.5 kW |
| | DO-160, Waveform 3, Level 4 | 5KP170C | 5 kW |
| | DO-160, Waveform 4, Level 3 | 5KP170C | 5 kW |
| | DO-160, Waveform 4, Level 4 | 20KP172C | 20 kW |

Note: Smaller packages than 400W are available for this combination of voltages.

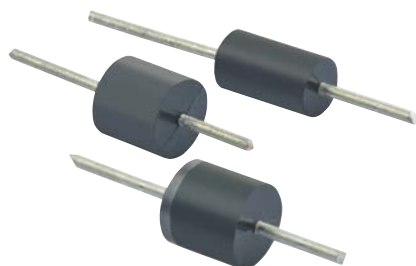

Examples of Axial Leaded TVS Packages

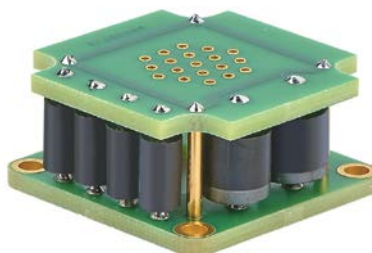

Subassembly Module Showing a Selection of TVS Axial Leaded Packages

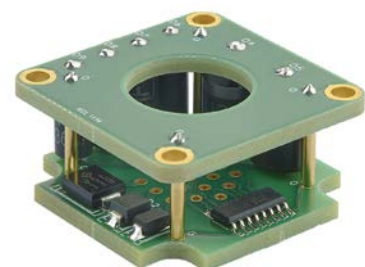

Subassembly Module with Selection of TVS Surface Mount Packages



Filtering Technologies

TYPICAL TRANSIENT PROTECTION PACKAGE SIZES

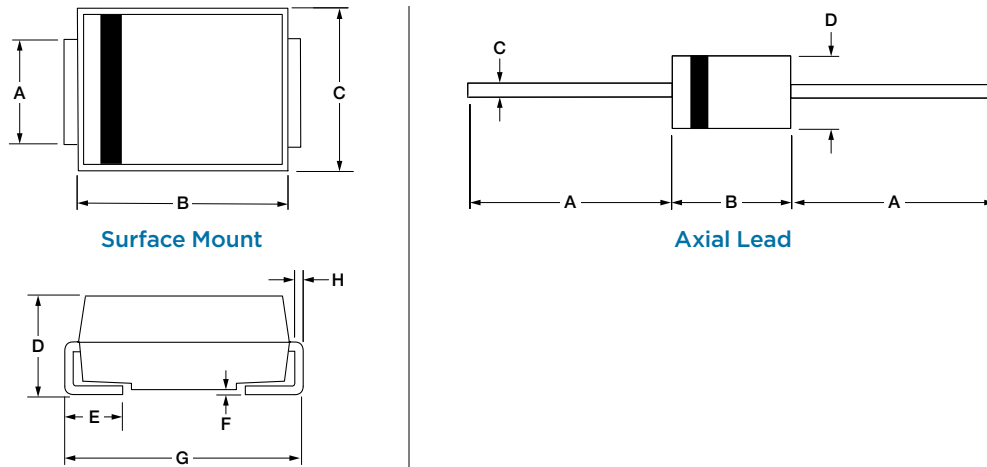

| Surface Mount | | | Axial Lead | | |
|---------------|--------------|--------------------|------------|--------------|--------------------|
| Package | Power Rating | Stand-Off Voltages | Package | Power Rating | Stand-Off Voltages |
| DO-214AC | 400 W | 5.8 V to 468 V | DO-41 | 400 W | 5.8 V to 468 V |
| DO-214AA | 600 W | 5.8 V to 468 V | DO-15 | 500 W | 5 V to 180 V |
| DO-214AA | 1 kW | 5.8 V to 153 V | DO-15 | 600 W | 5.8 V to 512 V |
| DO-214AB | 1.5 kW | 5.8 V to 468 V | DO-201 | 1.5k W | 5.8 V to 512 V |
| DO-214AB | 3.0 kW | 5 V to 170 V | P-600 | 5k W | 5 V to 250 V |
| DO-214AB | 5.0 kW | 12 V to 170 V | P-600 | 15 kW | 17 V to 280 V |
| — | — | — | P-600 | 20 kW | 20 V to 300 V |
| — | — | — | P-600 | 30 kW | 28 V to 300 V |

Package Reference: Dimensions (mm)

| Dim. | Surface Mount | | | Axial Lead | | | |
|------|---------------|----------|----------|------------|-------|--------|-------|
| | DO-214AC | DO-214AA | DO-214AB | DO-41 | DO-15 | DO-201 | P-600 |
| A | 1.45 | 2.08 | 3.05 | 25 | 25 | 25 | 25 |
| B | 4.25 | 4.31 | 6.86 | 4.65 | 6.70 | 8.35 | 8.85 |
| C | 2.66 | 3.62 | 5.90 | Ø0.78 | Ø0.78 | Ø1.02 | Ø1.27 |
| D | 2.14 | 2.28 | 2.34 | Ø2.35 | Ø3.10 | Ø5.05 | Ø8.85 |
| E | 1.15 | 1.15 | 1.15 | — | — | — | — |
| F | 0.10 | 0.10 | 0.10 | — | — | — | — |
| G | 5.11 | 5.40 | 7.94 | — | — | — | — |
| H | 0.22 | 0.22 | 0.22 | — | — | — | — |



Reference

Intermateability

The table below shows mating compatibility of DEUTSCH filter connectors with various military and aerospace standards.

| Connector Specification | H91 | HDJ | H92 | H93 | H94 | RR | 983 | 984 | AS | 5015 | A600 | LL |
|--------------------------|-----|-----|-----|-----|-----|----|-----|-----|----|------|------|----|
| ARINC 600 | | | | | | | | | | | ■ | |
| EN 3372 | | ■ | | | | | | | ■ | | | |
| ESC 10 | | | | | | | ■ | | | | | |
| ESC 11 | | | | | | | | ■ | | | | |
| ESC 15 | | | | | | | ■ | | | | | |
| ESC 16 | | | | | | | | ■ | | | | |
| HE 308 | ■ | | | | | | | | | | | |
| JN 1003 | | ■ | | | | | | | ■ | | | |
| LN 29500 | | | | | | ■ | | | | | | |
| LN 29729 | | ■ | | | | | | | ■ | | | |
| MIL-C-26482-I | | | | | | ■ | | | | | | |
| MIL-C-26482-II | | | | | | ■ | | | | | | |
| MIL-C-5015 | | | | | | | | | | ■ | | |
| MIL-C-81511 | | | | | | | | | | | | ■ |
| MIL-C-83723-I | | | | | | ■ | | | | | | |
| MIL-C-83723-III | | | | | | | ■ | | | | | |
| MIL-DTL-38999 Series 1 | ■ | | | | | | | | | | | |
| MIL-DTL-38999 Series 1.5 | | ■ | | | | | | | ■ | | | |
| MIL-DTL-38999 Series 2 | | | ■ | | | | | | | | | |
| MIL-DTL-38999 Series 3 | | | | ■ | | | | | | | | |
| MIL-DTL-38999 Series 4 | | | | | ■ | | | | | | | |
| NAS 1599 | | | | | | ■ | | | | | | |
| NF-C-93422 | ■ | | | | | | | | | | | |
| NFL 54125 | | | | | | ■ | | | | | | |
| Pan 6432-1 | | | | | | ■ | | | | | | |
| Pan 6432-4 | | | | | | ■ | | | | | | |
| Pan 6433-2 | | ■ | | | | | | | | | | |
| Pattern 105 | | | | | | ■ | | | | | | |
| Pattern 602 | | | | | | ■ | | | | | | |
| Pattern 603 | | | | | | ■ | | | | | | |
| Pattern 615 | | ■ | | | | | | | ■ | | | |
| VG 96912 | | ■ | | | | | | | ■ | | | |



Reference USING DEUTSCH FILTER CONNECTORS

Recommendations for PCB Mounting

DEUTSCH filter connectors are suitable for hand, wave, or reflow soldering to a PCB or flexible circuit. However, every effort should be made to prevent the internal hot spot temperature exceeding 150°C. If your requirements exceed this temperature, please contact us. See IPC-A-610E for workmanship criteria.

To provide mechanical strength and relieve stress on electrical connections, we recommend the use of a second PCB mounting flange.

Recommended PCB Hole Dimensions

When using DEUTSCH standard PCB tail diameters, we suggest the following hole and pad diameters be used.

| Contact Size | PCB Tail Dia. Max. | PCB Hole Dia. (=Tail Dia. + 0.5 mm (0.020)) | Solder Pad Dia. (=1.8 x Hole Dia.) |
|--------------|--------------------|---|------------------------------------|
| 22 | 0.56 (0.022) | 1.05 ± 0.05 (0.041 ± 0.002) | 1.90 (0.075) |
| 20 | 0.81 (0.032) | 1.30 ± 0.05 (0.051 ± 0.002) | 2.35 (0.093) |
| 16 | 1.02 (0.040) | 1.50 ± 0.05 (0.059 ± 0.002) | 2.70 (0.106) |
| 12 | 1.70 (0.067) | 2.15 ± 0.05 (0.085 ± 0.002) | 3.90 (0.154) |

Cleaning Procedures (IPC-M-108)

After soldering the connector to either a PCB or a cable harness, it is usually necessary to remove flux residue by cleaning the assembly. Since the sealing for virtually all connectors (filtered or standard) is only designed to work in a mated condition, these connectors must not be immersed in solvent or aqueous cleaner. Solvents can cause the sealing components to swell or deform, and the use of any liquid cleaner can allow the possibility of moisture ingress, which may not be fully removed during any subsequent drying operations. We strongly recommend against the use of solvents and suggests one of two cleaning methods be employed for cleaning all connectors with aqueous cleaner.

1. Clean only the PCB and contacts without allowing the cleaner to come into contact with the connector.

2. Interface the connector with either a fully populated mating half or a specially designed sealing cap prior to immersion or cleaning. Caps for the most common connector types are available. The caps can be used as an item of tooling on the assembly line to resolve this common query. Details can be provided on request.

Panel Sealing/Electrical Bonding

Filter connectors rely on a good ground path through the shell to the chassis or mounting panel. This must be considered when selecting the method of sealing the connector to the mounting panel. A standard gasket can insulate the connector from the ground plane, limiting or inhibiting the filter performance. Therefore, we recommend the use of conductive gaskets when sealing is required. These can be supplied with the connector if required.

Solder Bucket Termination Dimensions

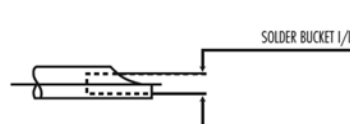

| Contact Size | Solder Bucket ID (Min.) |
|--------------|-------------------------|
| 22 | 0.90 (0.035) |
| 20 | 1.06 (0.042) |
| 16 | 1.75 (0.069) |

Recommendations for Wiring Solder Buckets

- Use a suitable flux and a solder that is compatible with the materials.
- Every effort should be made to prevent the internal hidden part of the contact from exceeding 150°C. Therefore, it is recommended that heat sinks be used.
- The minimum amount of heat required to achieve suitable quality should be applied to the joint.
- IPC-A-610E provides details on industry-accepted workmanship criteria.
- Contacts should be protected from high forces when soldering or testing joints.



Reference WIRE PREPARATION

A fundamental aspect of preparing a good crimp is the work required prior to the removal of the connector from its bag. The wire must be prepared correctly in order to ensure that the crimp is as secure and efficient as possible.

The first action that must be taken is to cut the wire to the required length. The wire-cutting tool must be sharp enough to create a clean, square cut (i.e., 90 degrees across the wire). If the wire is not cut square, this will leave strands of the conductor at different lengths. If a crimp is attempted with the wire in this condition, not all of the conductor strands will be inserted into the crimp bucket of the contact to a sufficient depth. This could potentially weaken the final crimp. When the wire has been cut correctly, the next step is to strip the insulation. In order to carry out this task correctly, a professional wire-stripping tool is required. There are several on the market, but as is the case with any tool used in harness work, a higher quality tool will result in a higher quality final product.

We recommend a tool with wire gauges that also employs a mechanical action to strip the insulation. Stripping tools that rely on manual strength to strip the insulation can often result in damage to the wire, with one or more of the conductor strands being removed, which is undesirable.

When the insulation has been removed NEVER twist the strands of wire. Doing so changes the diameter of the wire which may mean it cannot easily enter the contact bucket.

This practice also causes different strands to be under different stress levels, thus the crimp will never have an equal finish.

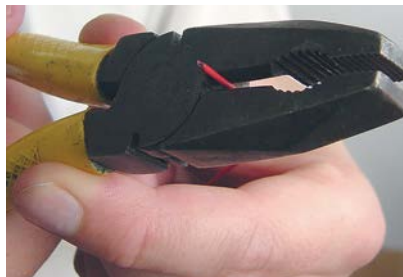

Not the best way to strip insulation. Pliers may remove the insulation, but are also likely to break and remove strands of the wire too.



Wire stripping with a recommended tool will allow the insulation to be removed accurately without damaging the wires.

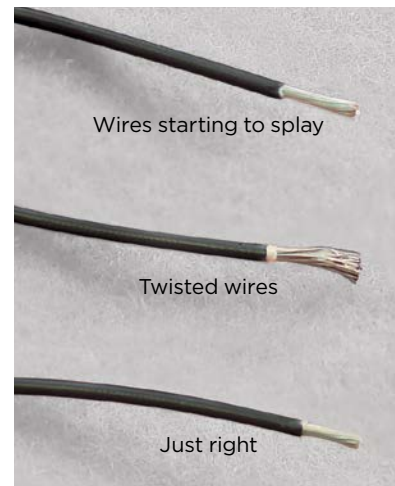

Suggested Wire Strip Lengths

Exact lengths for wire strips should be included in each harness house's formal technical procedures, but as a general recommendation, no more than 1mm of the conductor should be left exposed after crimping. If after a 'test insertion' is carried out, more of the conductor is left exposed than is required, then more of the conductor can be trimmed from the end of the wire. Again, a sharp wire-cutting tool should be used in order to ensure that the cut is clean and square.



An example of a good crimp showing the exposed wire.

There is a degree of flexibility regarding the length of strip required. As a guide, the final product should allow a small (1 mm) length of exposed conductor visible from the back end of the contact when the wire is FULLY inserted into the crimp bucket. This will allow movement of the wire without damaging the crimp. If the insulation is cut too close to the back end of the contact, this could subject the crimp to extra stress.



Reference CRIMPING

The single most important aspect of connector best practice is the crimp. The crimp process for DEUTSCH connectors employs identical technology to that of the MIL-C-39029 military standard. Selecting the correct crimp tool and positioner for the required contact is vital. See reference chart for contacts on page 30.

Two crimp tools and a variety of crimp positioners are the only equipment required for the entire range of DEUTSCH contacts with the exception of ASHD, for which special tooling is required.



The Crimping Concept

The term 'crimping' refers to a method of firmly attaching a terminal or contact to the end of an electrical conductor by pressure forming or reshaping a metal barrel onto the connector. The forming of a satisfactory crimp is dependant upon the correct combination of conductor, crimp barrel and crimping tool.

When the correct combination of equipment is employed, a crimp that has both good electrical and mechanical characteristics will be formed. Reliability of tooling and repeatability of the crimp can be ensured by using the recommended gauges to check the tools. These should be regularly calibrated.

The electrical resistance of a correctly designed and controlled crimp joint should be equal to, or less than that of an equal section of wire. The requirements regarding millivolt drop at a designated current can be found on page 62.

The mechanical strength of a crimped joint and hence its pull-off force (tensile strength) can vary according to the deformation applied. Therefore, a properly deformed crimp will result in a high pull-off force. In summary, the crimp die of the tool directly determines the crimp configuration and deformation.



Example of a poor crimp showing deformation of the inspection hole against a correct example. This is caused by incorrect tool settings.

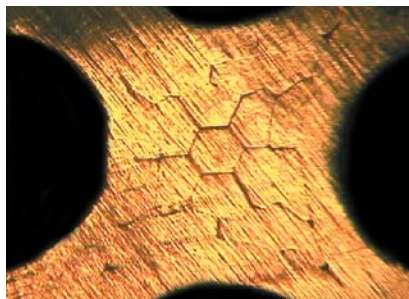

A good crimp showing the individual wires compressed evenly.

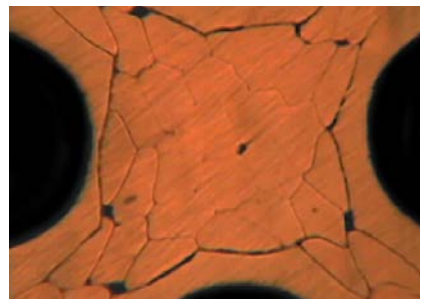

A poor, over compressed crimp showing the wires being forced unevenly and leaving fractures in the contact bucket.



Reference

ACCEPTANCE CRITERIA/VOLTAGE DROP TEST

Visual Inspection

During visual inspection the following acceptance criteria should apply:

1. The wire insulation should not have been damaged during the crimping process.
2. The conductor should be visible in the inspection hole of the contact.
3. The crimp barrel should have no sharp edges, cracked plating or cuts after the crimping process.
4. Tarnished or corroded contacts that were overlooked in the pre-assembly inspection should be cause for rejection.
5. Wrongly positioned crimps, as determined by marks found on areas where no crimp deformation should be found, should be cause for rejection.
6. Under-crimping (indicated by loose conductor) or over-crimping (indicated by broken conductor strands or deformation of the conductor at the end of the terminal) should be cause to stop work. All production crimps made since the last inspection or pull test should then be rejected. Tool settings, wire size and contacts should be inspected to determine the cause of crimp failure.
7. No attempt should be made to straighten bent contacts.

Connector barrel wire crimping

1. The required axial strength should be a minimum of 75% of the wire strength.
2. The bottom table details the minimum requirements for axial strength for copper and copper alloy wire; with either silver, tin or nickel-plated finishes.

Voltage DropTest

The voltage drop should be measured from a point on the positioning shoulder of the contact to another point 14mm distant on the attached wire. The voltage drop of the contact crimp joint should not exceed the value specified for each wire tested.

| Wire Barrel | Wire Size (awg) | Test Current | Max. Voltage Drop (mV) |
|-------------|-----------------|--------------|----------------------------------|
| | | | Silver or Tin Plated Copper Wire |
| 12 | 12 | 23 | 3.0 |
| | 14 | 17 | 3.5 |
| | 16 | 13 | 3.5 |
| 16 | 18 | 9.0 | 4.0 |
| | 20 | 7.5 | 4.0 |
| | 20 | 7.5 | 4.0 |
| 20 | 22 | 5.0 | 4.0 |
| | 24 | 3.0 | 4.0 |
| | 22 | 5.0 | 4.0 |
| 22 | 24 | 3.0 | 4.0 |
| | 26 | 2.0 | 4.0 |
| | 24 | 3.0 | 4.0 |
| 24 | 26 | 2.0 | 4.0 |
| | 28 | 1.5 | 5.0 |
| | 26 | 2.0 | 4.0 |
| 26 | 28 | 1.5 | 5.0 |
| | 28 | 1.5 | 5.0 |
| 28 | 28 | 1.5 | 5.0 |
| 30 | 30 | 1.5 | 5.0 |



Reference

ACCEPTANCE CRITERIA/VOLTAGE DROP TEST

Tensile Strength

The crimped contact-wire assemblies should be placed in a tensile testing device whose calibration is accurate to + 0.2 N, and an axial load applied at the rate of 25 (36.5) mm/minute. The connections should be loaded until failure occurs. The value at failure should be recorded, together with the information as to whether the failure was 'pull-out', 'broke-in-crimp' or 'break-in-wire'. The required minimum axial strengths for crimped joints are shown in the table below.

| Wire Barrel | Wire Size (awg) | Axial Strength (Newton) | |
|-------------|-----------------|----------------------------------|-------------------|
| | | Silver or Tin Plated Copper Wire | Copper Alloy Wire |
| 12 | 12 | 500 | — |
| | 14 | 320 | — |
| 16 | 16 | 230 | — |
| | 18 | 155 | — |
| | 20 | 90 | — |
| 20 | 20 | 90 | 185 |
| | 22 | 60 | 115 |
| | 24 | 40 | 60 |
| 22 | 22 | 60 | 115 |
| | 24 | 40 | 60 |
| | 26 | — | 45 |
| 24 | 24 | 40 | 60 |
| | 26 | — | 45 |
| | 28 | — | 30 |
| 26 | 26 | — | 45 |
| | 28 | — | 30 |
| 28 | 28 | — | 30 |
| 30 | 30 | — | 30 |



Reference

CONTACT INSERTION/EXTRACTION

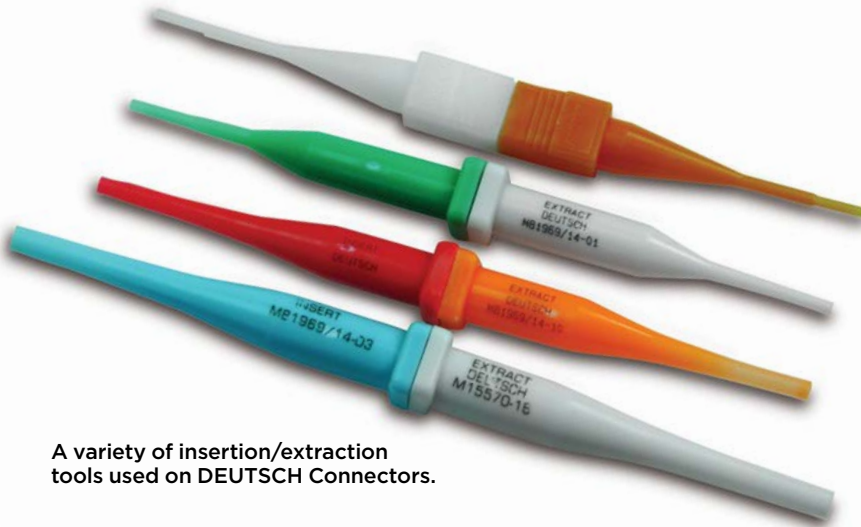

A variety of insertion/extraction tools used on DEUTSCH Connectors.

Contact Insertion/Extraction Tools

DEUTSCH connectors are supplied with the relevant insertion/extraction tool. It is essential that the correct, undamaged tool is used when inserting contacts into the connector. The tools are manufactured from a flexible plastic that will bend before causing any damage to the rear rubber of the connector.

Different specifications of military style connectors can have different characteristics and properties. For example, a MIL-DTL-26482 series connector has different diameters and tolerances inside the contact cavity to those inside a MIL-DTL-38999 connector. Therefore, in order to avoid damage to the connector, it is advisable to only use the insertion/extraction tool that was supplied with it.

It is recommended that a new tool is used for each connector. If a tool has become worn or if it has been rotated during the insertion of a contact, then parts of the tool can break off inside the contact cavity. This can permanently damage the retention tines and render the connector useless.

Isopropyl Alcohol – IPA

Through extensive testing, TE has discovered a number of processes that improve the assembly, installation and operation of DEUTSCH connectors.

As a result of these tests, TE has identified a lubricant; Propan-2-ol (Isopropyl Alcohol – IPA), which significantly aids contact insertion through the high integrity rear seal of the connector with greatly reduced effort. IPA will rapidly evaporate and leave no residue in the connector.

It is recommended that all contacts and insertion tools are dipped in a small pot (20 ml maximum) or safety container of IPA prior to contact insertion. Extraction tools should also be immersed in IPA prior to use. To prevent contamination only clean IPA should be used.

Regarding safety, the volumes of IPA being used should not cause a problem. However, it is recommended that users of IPA should refer to the relevant 'Health and Safety' and 'COSHH' data sheets. IPA is not warranted by TE for use on any other connector or any other manufacturer's connector unless otherwise specified.



Reference CONTACT INSERTION/EXTRACTION

Contact Insertion

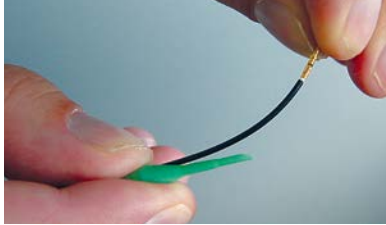

1. After a successful crimp, the contact can now be inserted into the connector. Using the insert/extraction tool provided, slide the wire, using your thumb, so that the wire is enclosed by the tool.



2. This image shows the wire successfully held in the tool.

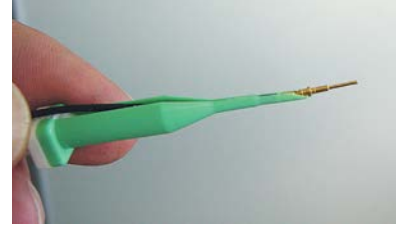

3. After gently pulling the wire through the tool, the contact will now be in position at the end of the tool. The contact should fit securely and the wire should not have any slack.



4. This image shows detail of the tines inside the connector. The process of inserting a contact into the connector will slide the contact into position, allowing the shoulder to pass beyond the tines, which will lock into position behind the shoulder. The insertion end of the tool is moulded at an angle to ease the contact into position. The extraction end of the tool is moulded with a straight end to 'unlock' the tines and allow contact removal.



5. This image shows a contact being dipped in IPA to lubricate the insertion process.



6. Contact being inserted through rear rubber of the connector. Insertion tool should NEVER be rotated, as this will damage the tool and the tines. If the tines get broken the contact may not be retained in the connector.



7. Once the tool has been fully inserted in the back of the connector. There will be a discernable 'click' as the shoulder of the contact passes through the tines and locks into position. The tool can then be removed leaving the contact locked into position. It is recommended either to use a contact retention test tool or give the wire a small tug to ensure the contact is installed correctly.

Contact Extraction

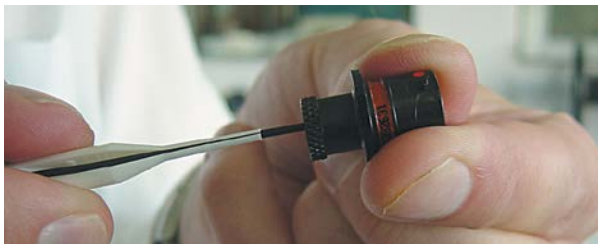

8. To remove a correctly installed contact, the other end of the tool is used. The extraction end of the tool has a flat aspect to enable all the tines to be unlocked together. The extraction end of the tool is inserted into the rear of the connector until the tines can be felt to unlock. Again, IPA can be used to lubricate the tool. A thumb should then be placed on the wire gripping the wire to the tool. The contact and wire can then be pulled from the back of the connector and a proper extraction can occur.



Reference BEST PRACTICES



All you need for successful connector use. Crimp tool, positioners, wire cutter and wire stripper.

1. Do not use scalpels or knives to strip wire insulation, unless instructed to do so.
2. Ensure wire strip does not damage the conductor strands.
3. The strip length must allow full depth location in the crimp bucket.
4. The strip length must not expose too much wire.
5. Do not pinch or twist the exposed wire strands.
6. All wire strands must be located in the crimp bucket.
7. Check the crimp settings on the crimp tool 'positioner' for the correct wire size.
8. The crimp tool should be calibrated periodically, dependant on use.
9. The crimp tool operation must fully close before release to ensure a full crimp.
10. Contacts must only be crimped once.
11. Always use an insertion/extraction tool that is in good condition.
12. Use lubrication for example, isopropyl alcohol to aid with contact insertion/extraction and prevent damage to the rubber.
13. Do not use excessive force to locate the contact.
14. The insertion/extraction tool is designed to buckle under excessive load. Continued use will cause damage to the tool and connector.
15. Do not use 'spare' insertion/extraction tools unless correctly identified. Do not rotate insertion/extraction tools in the connector. This will damage retention tines.
16. Always use a contact in a cavity even when unwired. This maintains the sealing integrity.
17. Always use filler plugs in unwired cavities to maintain sealing integrity.
18. Always use a contact and filler plug together.
19. Always place the head of the filler plug in the cavity for support.
20. Do not use metal insertion/extraction tools.
21. If necessary, check contact location using contact retention test tools.



Reference

CRIMP CONTACTS, TOOLING, AND SEALING PLUGS

Contact Current Ratings

The contact rating of any contact within the connector is governed by the heating effect of the current and the ambient temperature. Contact loading should not exceed:

- Size 22: 5A
- Size 20: 7.5 A
- Size 16: 13 A
- Size 12: 23 A

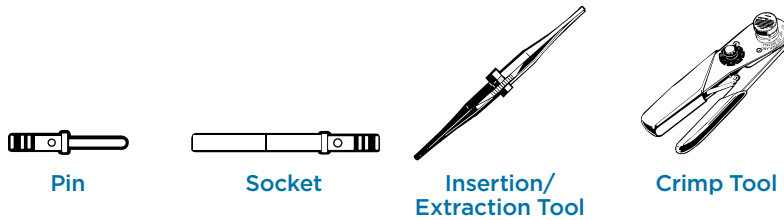

| Size | Contacts | | | | Ins/Ext Tool | Crimp Tooling | |
|------|-------------|-----------|-------------------------------|-------------------------------|--------------|---------------|---------------------------|
| | TE Part No. | | (AS39029) Slash ID | | | Tool | Positioner |
| | Pin | Socket | Pin | Socket | | | |
| 22 | 38941-22L | 38943-22L | /58-360 /87-471 /87-472 | /56-348 /89-495 /89-496 | M81969/14-01 | M22520/2-01 | M22520/2-09 M2250/2-07 |
| 20 | 38941-20L | 38943-20L | /58-363 | /56-351 | M15570-20 | M22520/1-01 | M22520/1-04 |
| 16 | 38941-16L | 38943-16L | /58-364 | /56-352 | M15570-16 | M22520/1-01 | M22520/01-04 |
| 12 | 38941-12L | 38943-12L | /58-365 | /56-353 | M15570-12 | M22520/1-01 | M22520/1-04 |

*Extraction only. Insertion is manual.

PCB Contacts

| Size | Pin | Socket |
|------|-------------|-------------|
| 22 | 724-0902-22 | 724-0904-22 |
| 20 | 724-0902-20 | 724-0904-20 |
| 16 | 724-0902-16 | 724-0904-16 |
| 12 | 724-0902-12 | 724-0904-12 |

Coaxial Contacts

| Size | Pin | | Socket | |
|------|----------|-------------|----------|-------------|
| | AS39029 | Part No. | AS39029 | Part No. |
| 16 | /76-424 | 724-0004-16 | /77-428 | 182-0013-16 |
| 12 | /102-558 | 182-0100-12 | /103-559 | 182-0101-12 |
| 8 | /59 | 182-0127-68 | /60 | 182-0128-68 |

Shielded Contacts

| Size | Pin | | Socket | |
|------|------------|-------------|------------|-------------|
| | Mil Spec | Part No. | Mil Spec | Part No. |
| 16 | NAS 938171 | 025-0847-00 | NAS 938172 | 025-0848-00 |
| 12 | AS39029/28 | 182-0098-12 | AS3902952 | 182-0099-12 |

Tooling for Coaxial and Triax Contacts

| Intermediate Contact | | Ferrule | | Tools | | Arrangements for Size 8 Contacts | |
|----------------------|-------------|-------------|-------------|-------------------------|--------------|----------------------------------|----------------------------------|
| Crimp Tool | Mark A | Crimp Tool | Mark A | Extraction | Key | Version | Arrangements |
| TDB-CT-08 | 057-0782-00 | M22520/5-01 | 057-0782-00 | 114-008 M81969-14-06 | DF 57-095-02 | A | 21-30 21-46 |
| TDB-CT-08 | 057-0782-00 | M22520/5-01 | 057-0782-00 | 114-008 M81969-14-06 | DF 57-095-02 | A | 21-30 21-46 |
| M22520/2-01 | 057-0782-00 | M22520/5-01 | 057-0782-00 | 114-008 M81969-14-06 | DF 57-095-02 | B | 11-01 to 11-75 17-28 to 21-75 |
| M22520/2-01 | 057-0782-00 | M22520/5-01 | 057-0782-00 | 114-008 M81969/14-6 | DF 57-095-20 | B | 11-01 to 11-75 17-28 to 21-75 |

Sealing Plugs

| Contact Size | Part No. | Color |
|--------------|-------------|--------|
| 22 | 028-0102-22 | Yellow |
| 20 | 006-0893-20 | Red |
| 16 | 006-0893-16 | Blue |
| 12 | 006-0893-12 | Yellow |



Reference WIRE GAUGE DATA

| Wire Size (AWG) | Diameter | | Turns of Wire | | Area | | Approx. Standard Metric Equiv. |
|--------------------|----------|--------|---------------|----------|---------|--------------------|--------------------------------------|
| | (inch) | (mm) | (per in) | (per cm) | (kcmil) | (mm ²) | |
| 0000 (4/0) | 0.460 | 11.684 | 2.17 | 0.86 | 212.00 | 107.00 | |
| 000 (3/0) | 0.410 | 10.404 | 2.44 | 0.96 | 168.00 | 85.00 | |
| 00 (2/0) | 0.365 | 9.266 | 2.74 | 1.08 | 133.00 | 67.40 | |
| (1/0) | 0.325 | 8.252 | 3.08 | 1.21 | 106.00 | 53.50 | |
| 1 | 0.289 | 7.348 | 3.46 | 1.36 | 83.70 | 42.40 | |
| 2 | 0.258 | 6.544 | 3.88 | 1.53 | 66.40 | 33.60 | |
| 3 | 0.229 | 5.827 | 4.36 | 1.72 | 52.60 | 26.70 | 196/0.4 |
| 4 | 0.204 | 5.189 | 4.89 | 1.93 | 41.70 | 21.20 | |
| 5 | 0.182 | 4.621 | 5.50 | 2.16 | 33.10 | 16.80 | 126/0.4 |
| 6 | 0.162 | 4.115 | 6.17 | 2.43 | 26.30 | 13.30 | |
| 7 | 0.144 | 3.665 | 6.93 | 2.73 | 20.80 | 10.50 | 80/0.4 |
| 8 | 0.129 | 3.264 | 7.78 | 3.06 | 16.50 | 8.37 | |
| 9 | 0.114 | 2.906 | 8.74 | 3.44 | 13.10 | 6.63 | 84/0.3 |
| 10 | 0.102 | 2.588 | 9.81 | 3.86 | 10.40 | 5.26 | |
| 11 | 0.091 | 2.305 | 11.00 | 4.34 | 8.23 | 4.17 | 56/0.3 |
| 12 | 0.081 | 2.053 | 12.40 | 4.87 | 6.53 | 3.31 | |
| 13 | 0.072 | 1.828 | 13.90 | 5.47 | 5.18 | 2.62 | 50/0.25 |
| 14 | 0.064 | 1.628 | 15.60 | 6.14 | 4.11 | 2.08 | |
| 15 | 0.057 | 1.450 | 17.50 | 6.90 | 3.26 | 1.65 | 30/0.25 |
| 16 | 0.051 | 1.291 | 19.70 | 7.75 | 2.58 | 1.31 | |
| 17 | 0.045 | 1.150 | 22.10 | 8.70 | 2.05 | 1.04 | 32/0.2 |
| 18 | 0.040 | 1.024 | 24.80 | 9.77 | 1.62 | 0.82 | 24/0.2 |
| 19 | 0.036 | 0.912 | 27.90 | 11.00 | 1.29 | 0.65 | |
| 20 | 0.032 | 0.812 | 31.30 | 12.30 | 1.02 | 0.52 | 16/0.2 |
| 21 | 0.029 | 0.723 | 35.10 | 13.80 | 0.81 | 0.41 | 13/0.2 |
| 22 | 0.025 | 0.644 | 39.50 | 15.50 | 0.64 | 0.33 | 7/0.25 |
| 23 | 0.023 | 0.573 | 44.30 | 17.40 | 0.51 | 0.26 | |
| 24 | 0.020 | 0.511 | 49.70 | 19.60 | 0.40 | 0.21 | 1/0.5, 7/0.2, 30/0.1 |
| 25 | 0.018 | 0.455 | 55.90 | 22.00 | 0.32 | 0.16 | |
| 26 | 0.016 | 0.405 | 62.70 | 24.70 | 0.25 | 0.13 | 1/0.4, 7/0.15 |
| 27 | 0.014 | 0.361 | 70.40 | 27.70 | 0.20 | 0.10 | |
| 28 | 0.013 | 0.321 | 79.10 | 31.10 | 0.16 | 0.08 | 7/0.12 |
| 29 | 0.011 | 0.286 | 88.80 | 35.00 | 0.13 | 0.06 | |
| 30 | 0.010 | 0.255 | 99.70 | 39.30 | 0.10 | 0.05 | 1/0.25, 7/0.1 |
| 31 | 0.009 | 0.227 | 112.00 | 44.10 | 0.08 | 0.04 | |
| 32 | 0.008 | 0.202 | 126.00 | 49.50 | 0.06 | 0.03 | 1/0.2, 7/0.08 |
| 33 | 0.007 | 0.180 | 141.00 | 55.60 | 0.05 | 0.03 | |
| 34 | 0.006 | 0.160 | 159.00 | 62.40 | 0.04 | 0.02 | |
| 35 | 0.006 | 0.143 | 178.00 | 70.10 | 0.03 | 0.02 | |
| 36 | 0.005 | 0.127 | 200.00 | 78.70 | 0.03 | 0.01 | |
| 37 | 0.004 | 0.113 | 225.00 | 88.40 | 0.02 | 0.01 | |
| 38 | 0.004 | 0.101 | 252.00 | 99.30 | 0.02 | 0.01 | |
| 39 | 0.004 | 0.090 | 283.00 | 111.00 | 0.01 | 0.01 | |
| 40 | 0.003 | 0.080 | 318.00 | 125.00 | 0.01 | 0.01 | |



Reference WIRE GAUGE DATA

| Wire Size (AWG) | Copper Resistance | | NEC Copper Wire Ampacity with 60/75/90 °C Insulation | Fusing Current (copper) | | |
|--------------------|-------------------|-----------------|---|-------------------------|-----------------|-------------------|
| | (Ω/km) (mΩ/m) | (Ω/kFT) (mΩ/ft) | | Preece (-10 s) | Onderdonk (1 s) | Onderdonk (32 ms) |
| 0000 (4/0) | 0.1608 | 0.0490 | 195 / 230 / 260 | | 31 kA | 173 kA |
| 000 (3/0) | 0.2028 | 0.0618 | 165 / 200 / 225 | | 24.5 kA | 137 kA |
| 00 (2/0) | 0.2557 | 0.0779 | 145 / 175 / 195 | | 19.5 kA | 109 kA |
| (1/0) | 0.3224 | 0.0983 | 125 / 150 / 170 | 1.9 kA | 15.5 kA | 87 kA |
| 1 | 0.4066 | 0.1239 | 110 / 130 / 150 | 1.6 kA | 12 kA | 68 kA |
| 2 | 0.5127 | 0.1563 | 95 / 115 / 130 | 1.3 kA | 9.7 kA | 54 kA |
| 3 | 0.6465 | 0.1970 | 85 / 100 / 110 | 1.1 kA | 7.7 kA | 43 kA |
| 4 | 0.8152 | 0.2485 | 70 / 85 / 95 | 946 A | 6.1 kA | 34 kA |
| 5 | 1.0280 | 0.3133 | | 795 A | 4.8 kA | 27 kA |
| 6 | 1.2960 | 0.3951 | 55 / 65 / 75 | 668 A | 3.8 kA | 21 kA |
| 7 | 1.6340 | 0.4982 | | 561 A | 3 kA | 17 kA |
| 8 | 2.0610 | 0.6282 | 40 / 50 / 55 | 472 A | 2.4 kA | 13.5 kA |
| 9 | 2.5990 | 0.7921 | | 396 A | 1.9 kA | 10.7 kA |
| 10 | 3.2770 | 0.9989 | 30 / 35 / 40 (but use a 30 A OCPD) | 333 A | 1.5 kA | 8.5 kA |
| 11 | 4.1320 | 1.2600 | | 280 A | 1.2 kA | 6.7 kA |
| 12 | 5.2110 | 1.5880 | 25 / 25 / 30 (but use a 20 A OCPD) | 235A | 955 A | 5.3 kA |
| 13 | 6.5710 | 2.0030 | | 198 A | 758 A | 4.2 kA |
| 14 | 8.2860 | 2.5250 | 20 / 20 / 25 (but use a 15 A OCPD) | 166 A | 601 A | 3.3 kA |
| 15 | 10.4500 | 3.1840 | | 140 A | 477 A | 2.7 kA |
| 16 | 13.1700 | 4.0160 | - / - / 18 | 117 A | 377 A | 2.1 kA |
| 17 | 16.6100 | 5.0640 | | 99 A | 300 A | 1.7 kA |
| 18 | 20.9500 | 6.3850 | - / - / 14 | 83 A | 237A | 1.3 kA |
| 19 | 26.4200 | 8.0510 | | 70 A | 189 A | 1 kA |
| 20 | 33.3100 | 10.1500 | | 58.5 A | 149 A | 834 A |
| 21 | 42.0000 | 12.8000 | | 49 A | 119 A | 662 A |
| 22 | 52.9600 | 16.1400 | | 41 A | 94 A | 525 A |
| 23 | 66.7900 | 20.3600 | | 35 A | 74 A | 416 A |
| 24 | 84.2200 | 25.6700 | | 29 A | 59 A | 330 A |
| 25 | 106.2000 | 32.3700 | | 24 A | 47 A | 262 A |
| 26 | 133.9000 | 40.8100 | | 20 A | 37 A | 208 A |
| 27 | 168.9000 | 51.4700 | | | | |
| 28 | 212.9000 | 64.9000 | | | | |
| 29 | 268.5000 | 81.8400 | | | | |
| 30 | 338.6000 | 103.2000 | | | | |
| 31 | 426.9000 | 130.1000 | | | | |
| 32 | 538.3000 | 164.1000 | | | | |
| 33 | 678.8000 | 206.9000 | | | | |
| 34 | 856.0000 | 260.9000 | | | | |
| 35 | 1079.0000 | 329.0000 | | | | |
| 36 | 1361.0000 | 414.8000 | | | | |
| 37 | 1716.0000 | 523.1000 | | | | |
| 38 | 2164.0000 | 659.6000 | | | | |
| 39 | 2729.0000 | 831.8000 | | | | |
| 40 | 3441.0000 | 1049.0000 | | | | |



Typical DEUTSCH Filter Connector Part Number Scheme

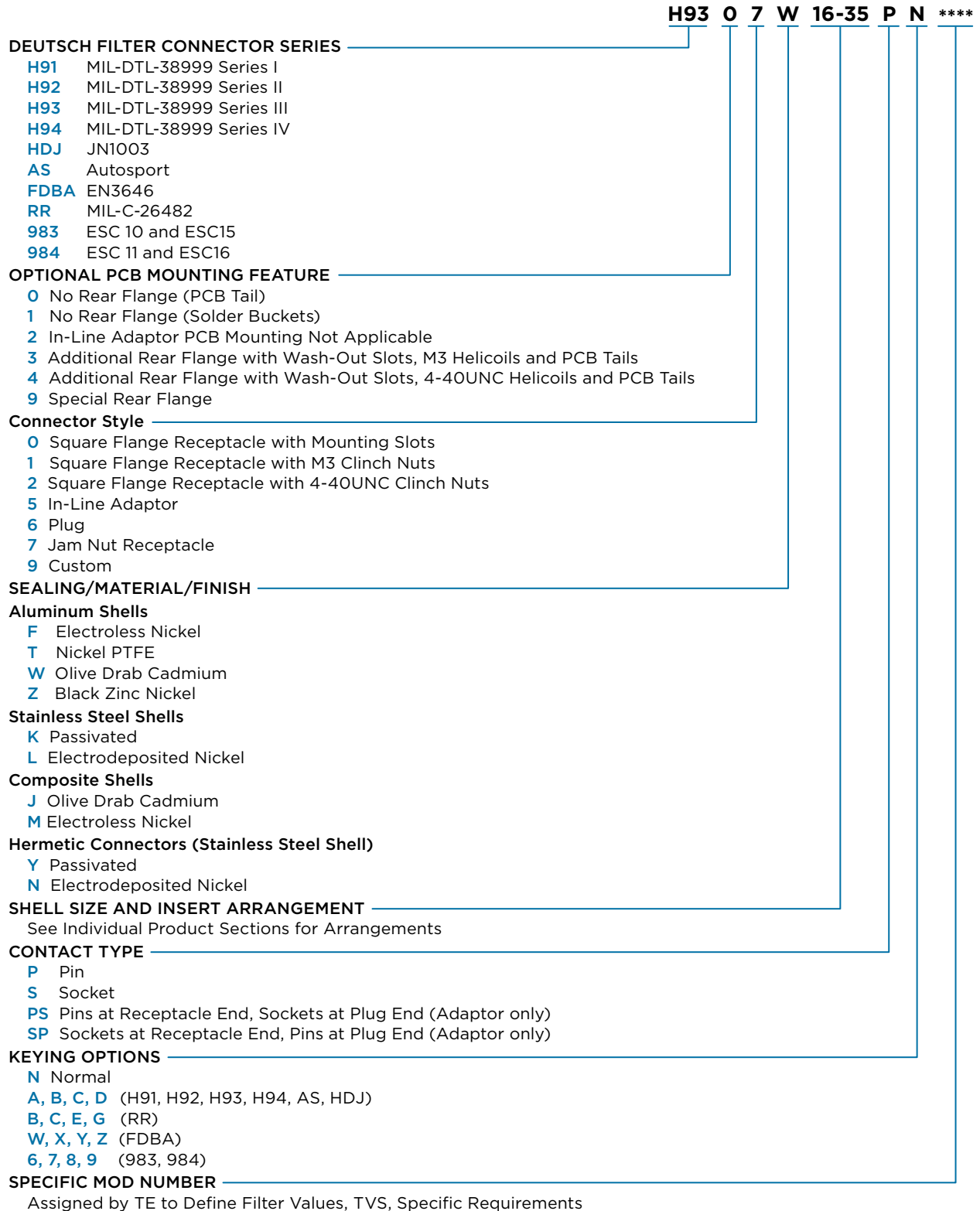



Glossary

Attenuation. A measure of filtering, expressed in decibels (dB). It is a measure of how effectively the filter reduces the strength of a given frequency. The higher the number, the better the filtering. In general, attenuation of 40 to 70 dB is a good target.

Breakdown Voltage. The threshold voltage at which the diode goes into avalanche.

C Filter. A filter using a capacitor.

Capacitance. For filter connectors, capacitance presents low reactance to high frequencies and high reactance to low frequencies: it passes high frequencies and blocks low frequencies.

Used to shunt high-frequency EMI to ground.

Capacitance is measured in farads, most commonly in microfarads (10^{-6} or millionths of a farad), nanofarads (10^{-9} or billionths), or picofarads (10^{-12} or trillionths).

Clamping Voltage. The maximum voltage to which the TVS device will clip any transient voltages.

Cutoff Frequency is the point at which the filter is considered to start filtering. It is 3 dB of attenuation.

Decibel. The ratio between two currents, voltages, or power. For filter connectors, decibel is most often used to measure the loss (filtering) at a given frequency. It is a comparison of power levels without a filter and with a filter inserted into the system.

Dielectric Withstand Voltage (DWV). A measure of an insulator's ability to withstand high voltages without breakdown or failure in maintaining its insulating properties.

Diode Standoff Voltage. The minimum voltage that can be applied to the diode without it switching.

Double-T Filter. A filter composed of two T filters. It has five elements, typically three inductors and two capacitors.

EMI. Electromagnetic interference. Any unwanted conducted or radiated electrical energy.

EMP. Electromagnetic pulse. A voltage transient of short duration and high magnitude. Examples include lightning and nuclear explosions.

Filter Band. The range of frequencies that are filtered, beginning at the 3-dB cutoff frequency.

HEMP. High-altitude electromagnetic pulse. EMP caused by a nuclear explosion miles above the earth.

Impedance. The sum of the resistive and reactive components in an AC circuit, which represents the total resistance of that circuit (symbol is Z).

Inductance. For filter connectors, inductance presents high reactance to high frequencies and low reactance to low frequencies: it passes low frequencies and blocks high frequencies.

Insertion Loss. The reduction in power that takes place at the load when a device (such as a connector) is inserted into the circuit between the source and load. Expressed in decibels, it defines the difference before and after the device is inserted.

Insulation Resistance (IR). The electrical resistance of an insulating material, typically measured between two

conductors or a conductor and ground. The value is typically several million ohms (megohms).

L Filter. A filter using an inductor (or several inductors) only.

LC or CL Filter. A filter using both a capacitor and an inductor.

LEMP. Lightning electromagnetic pulse. EMP caused by a lightning strike.

Low-Pass Filter. A filter designed to pass lower frequencies and filter high frequencies. The most common type of EMI filter and the type used in filter connectors.

Metal-Oxide Varistor (MOV). A device whose resistance varies with voltage, used to suppress transient voltages. Varistor is a shortened form of variable resistor.

NEMP. Nuclear electromagnetic pulses. EMP caused by a nuclear explosion.

Passband. The range of frequencies that are not filtered—that is, they are passed through the filter.

Peak Impulse Current. The maximum current that the TVS device can handle as the result of a transient

Peak Pulse Power Dissipation. A TVS device's capability for dissipating energy. Peak pulse power dissipation is calculated by multiplying the clamping voltage by the peak impulse current ($PPP = V_{CLAMP} \times I_{MAX}$)

Pi Filter. A filter using two capacitors and one inductor for a low-pass configuration; named after the shape of the schematic symbols.

Planar Capacitor Array. A monolithic construction technique for capacitive filters, arrays offer a compact, low-profile form factor well suited for use in connectors. A single array can accommodate all contacts in a connector; filter values can be the same for all contacts or have different values for each contact.

Reactance. Resistance to changes in voltage (capacitive reactance) or current (inductive reactance). Reactance is frequency dependent.

RFI. Radio frequency interference. A type of EMI that occurs in the radio frequency bands.

Slope. Filtering goes from no filtering to maximum filtering over a range of frequencies. The slope shows attenuation versus frequency. A steep slope is desirable, but requires more complex filtering.

T Filter. A filter having two filter elements in the pass path and one element in the ground (filter) path. For a low-pass EMI filter, the circuit has two inductors and one capacitor. Used when both the source and load have low impedances.

TVS. Transient voltage suppression. Any of several techniques to suppress electromagnetic pulses by clamping voltage transients to acceptable levels. The most common TVS device used for filter connectors is the zener diode.

Zener Diode. A semiconductor device that allows current to flow in the forward direction like a standard diode, but also permits current in the reverse direction when the voltage when the voltage exceeds a certain level. Used for transient suppression.



TE Filtered Product Configuration Sheet

Customer reference for this connector:

Please complete one sheet per connector.
Mark your selection with an X.

Mil Spec (i.e., 38999 S III) or TE Range (i.e., H93)

Insert arrangement/platform

Orientation/Keyway (e.g. N)

MECHANICAL REQUIREMENTS

Connector Type

- Square Flange Receptacle Plug Adaptor
- Jam Nut Receptacle Bulkhead Feedthrough

(Product dimensions can be designed to specific requirements)

Shell mounting style (Receptacles Only)

- Square Flange with Mounting Slots
- Square Flange with M3 Threaded Inserts
- Square Flange with 4-40 UNC Threaded Inserts
- Jam Nut with Conductive O-Ring (Nonconductive O-Ring is Standard)

Optional PCB mounting feature (Receptacles Only)

- None
- Additional Rear Flange with Wash Out Slots and M3 Helicoils
- Additional Rear Flange with Wash Out Slots and 4-40 UNC Helicoils
- Header Assembly – M3 Helicoils
- Header Assembly – 4-40 UNC Helicoils

Rear termination (Receptacles and Plugs)

- 2.5 mm (0.098") PC Tails
- 3.18 mm (0.125") PC Tails
- 5.0 mm (0.197") PC Tails
- 6.5 mm (0.256") PC Tails
- 8.0 mm (0.315") PC Tails
- 3.20 mm (0.126") Solder buckets
- Pre-wired (enter details in box provided)
- Header Assembly pins

Rear termination finish (Receptacles and Plugs)

- Gold Plated (Tails or buckets)
- Tin Dipped (PC tails only)

Shell material (All Connector Types)

- Aluminium Alloy
- Stainless Steel
- Composite

Shell Surface Finish (All Connector Types)

- Electroless Nickel
- Cadmium/Olive Drab
- Passivate (Stainless Steel Only)
- Black Zinc Nickel
- PTFE Nickel (Aluminium Alloy Only)

Mating Interface (Receptacles and Plugs Only)

- Pins
- Sockets

Mating Interface(s) (Adaptors Only)

- SPN (Sockets at receptacle end and pins at the plug end)
- PSN (Pins at the receptacle end and sockets at the plug end)

ELECTRICAL REQUIREMENTS

Maximum working voltage AC/DC

Tick all that apply

- 50 VDC 50 VAC
- 100 VDC 100 VAC
- 200 VDC 200 VAC
- 500 VDC 500 VAC
- 1000 VDC 1000 VAC
- Other (please specify)

Dielectric withstand voltage

Tick all that apply

- 125 VDC 125 VAC
- 250 VDC 250 VAC
- 500 VDC 500 VAC
- 750 VDC 750 VAC
- 1000 VDC 1000 VAC
- 1500 VDC 1500 VAC
- Other (please specify)

Filter topology (Specify transient protection on additional sheet)

Tick all that apply

If mixed filtering is required on the connector, please identify the requirements below, or on the next page.

- L Pi
- CL T
- LC Double T

Filter Value (Total Capacitance per contact)

Tick all that apply

If mixed filter values, grounded or feedthrough lines or TVS devices are required, please identify the requirements for each contact below, or on the next page.

- 0.5 nF Grounded
- 1 nF Feedthrough (unfiltered)
- 2.5 nF TVS Protection
- 5 nF Other (please specify)
- 10 nF Please state requirements on page 2
- 15 nF
- 20 nF

Additional Notes:

TE Connectivity will release this connector against the controlled documents listed below at the latest issue. Page 1 of 2

For TE Connectivity Use Only:

Document No./TE Part No.: _____ Issue No.: _____ Date: _____

TE Envelope Drawing: _____ Issue No.: _____ Date: _____

In the event that a specific configuration is not available TE will advise by return.



Additional Filter Connector Capabilities

Specific Requirements per Contact

Customer Reference for This Connector _____

If necessary, please indicate your individual pin filter requirements – for filter value, topology, TVS, and other needs – against the relevant contact number below.

| Contact No. | Requirement | Contact No. | Requirement | Contact No. | Requirement | Contact No. | Requirement |
|-------------|-------------|-------------|-------------|-------------|-------------|-------------|-------------|
| 1 | | 33 | | 65 | | 97 | |
| 2 | | 34 | | 66 | | 98 | |
| 3 | | 35 | | 67 | | 99 | |
| 4 | | 36 | | 68 | | 100 | |
| 5 | | 37 | | 69 | | 101 | |
| 6 | | 38 | | 70 | | 102 | |
| 7 | | 39 | | 71 | | 103 | |
| 8 | | 40 | | 72 | | 104 | |
| 9 | | 41 | | 73 | | 105 | |
| 10 | | 42 | | 74 | | 106 | |
| 11 | | 43 | | 75 | | 107 | |
| 12 | | 44 | | 76 | | 108 | |
| 13 | | 45 | | 77 | | 109 | |
| 14 | | 46 | | 78 | | 110 | |
| 15 | | 47 | | 79 | | 111 | |
| 16 | | 48 | | 80 | | 112 | |
| 17 | | 49 | | 81 | | 113 | |
| 18 | | 50 | | 82 | | 114 | |
| 19 | | 51 | | 83 | | 115 | |
| 20 | | 52 | | 84 | | 116 | |
| 21 | | 53 | | 85 | | 117 | |
| 22 | | 54 | | 86 | | 118 | |
| 23 | | 55 | | 87 | | 119 | |
| 24 | | 56 | | 88 | | 120 | |
| 25 | | 57 | | 89 | | 121 | |
| 26 | | 58 | | 90 | | 122 | |
| 27 | | 59 | | 91 | | 123 | |
| 28 | | 60 | | 92 | | 124 | |
| 29 | | 61 | | 93 | | 125 | |
| 30 | | 62 | | 94 | | 126 | |
| 31 | | 63 | | 95 | | 127 | |
| 32 | | 64 | | 96 | | 128 | |

Additional Notes

DEUTSCH, TE, TE Connectivity, TE connectivity (logo) and Every Connection Counts are trademarks. All other logos, products and/or company names referred to herein might be trademarks of their respective owners.

The information given herein, including drawings, illustrations and schematics which are intended for illustration purposes only, is believed to be reliable. However, TE Connectivity makes no warranties as to its accuracy or completeness and disclaims any liability in connection with its use. TE Connectivity's obligations shall only be as set forth in TE Connectivity's Standard Terms and Conditions of Sale for this product and in no case will TE Connectivity be liable for any incidental, indirect or consequential damages arising out of the sale, resale, use or misuse of the product. Users of TE Connectivity products should make their own evaluation to determine the suitability of each such product for the specific application.

© 2016 TE Connectivity Ltd. family of companies All Rights Reserved.

1-1773870-7 03/16 Original

Tel: +44(0) 1793616700 • Fax: +44(0) 1793 644304
uksales@is-rayfast.com • export@is-rayfast.com

www.is-rayfast.com

2 Lydiard Fields, Swindon, Wiltshire, SN5 8UB

